

# aiwa

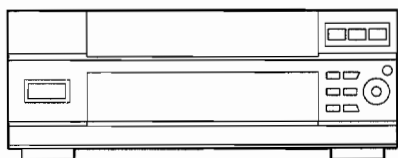

## AM-X10



MINIDISC RECORDER

• BASIC MD MECHANISM: 6ZG-5A2

• TYPE: EZ

改 定 版

### REVISION PUBLISHING

このサービスマニュアルはシンプル版 (S/M Code No. 09-977-217-90T) の改定版です。  
差し替えて使用してください。

This Service Manual is the "Revision Publishing" and replaces "Simple Manual"  
(S/M Code No. 09-977-217-90T).

## TABLE OF CONTENTS

SPECIFICATIONS .....	3
TRANSISTOR ILLUSTRATION .....	3
PROTECTION OF EYES FROM LASER BEAM DURING SERVICING .....	4
PROTECTION TO REPLACE OPTICAL BLOCK .....	4
MD DISASSEMBLY INSTRUCTIONS .....	5~12
ELECTRICAL MAIN PARTS LIST .....	13~15
WAVE FORM .....	16
BLOCK DIAGRAM .....	17~19
WIRING-1 (MD MAIN) .....	20~22
SCHEMATIC DIAGRAM-1 (MD MAIN) .....	23~25
WIRING-2 (FRONT) .....	26~28
SCHEMATIC DIAGRAM-2 (FRONT) .....	29~30
WIRING-3 (MAIN) .....	31~32
SCHEMATIC DIAGRAM-3 (MAIN) .....	33~34
WIRING-4 (MOTOR) .....	35
SCHEMATIC DIAGRAM-4 (MOTOR) .....	36
SCHEMATIC DIAGRAM-5 (DRV) .....	37~38
IC BLOCK DIAGRAM .....	39~40
IC DESCRIPTION .....	41~52
FL GRID ASSIGNMENT/ANODE CONNECTION .....	53~54
ADJUSTMENT .....	55~57
TEST MODE .....	58~61
MECHANICAL EXPLODED VIEW-1/1 .....	62
MECHANICAL PARTS LIST-1/1 .....	63
MD MECHANISM EXPLODED VIEW-1/2 .....	64~65
MD MECHANISM PARTS LIST-1/2 .....	66
MD MECHANISM EXPLODED VIEW-2/2 .....	67
MD MECHANISM PARTS LIST-2/2 .....	68
ACCESSORIES / PACKAGE LIST .....	69

## SPECIFICATIONS

### MINI DISC RECORDER AM-X10

<b>Disc</b>	MiniDisc
<b>Scanning method</b>	Non-contact optical scanner (Semiconductor laser application)
<b>Recording system</b>	Magnetic polarity modulation overwrite system
<b>Rotation speed</b>	Aprox. 400 - 900 rpm (CLV)
<b>Sampling frequency</b>	44.1 kHz
<b>No. of channels</b>	Stereo: 2 channels Monaural: 1 channel
<b>A-D, D-A converter</b>	1-bit
<b>Frequency</b>	20 - 20000 Hz +0.5 - -1.0 dB
<b>Wow and flutter</b>	Unmeasurable (±0.001% W.PEAK)
<b>Input</b>	RCA phono jack (REC/LINE IN) Optical cable jack (DIGITAL IN (OPTICAL))
<b>Output</b>	RCA phono jack (PLAY/LINE OUT) Optical cable jack (DIGITAL OUT (OPTICAL)) Headphones jack (PHONES, stereo minijack)
<b>Power</b>	230 V AC, 50 Hz
<b>Power consumption</b>	16 W
<b>Dimension (W × D × H)</b>	260 × 325.1 × 88.5 mm
<b>Weight</b>	3.0 kg

### SPEAKER SYSTEM SX-NAVH80

<b>Cabinet type</b>	3 way, bass reflex (magnetic shielded type)
<b>Speakers</b>	Woofer: 160 mm cone type Tweeter: 60 mm cone type Super tweeter: 20 mm ceramic type
<b>Impedance</b>	6 ohms
<b>Output sound pressure level</b>	88 dB/W/m
<b>Dimensions (W × H × D)</b>	250 × 396 × 250 mm
<b>Weight</b>	5 kg

● Design and specifications are subject to change without notice.

### TRANSISTOR ILLUSTRATION

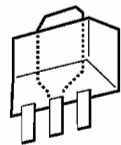

2SA1213

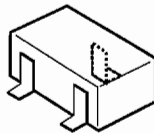

2SA1588  
2SC4116  
DTA114EK  
DTC114EK  
RN2305

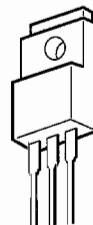

BCE  
2SB1370



ECB  
2SC1740S  
DTA123JS  
DTC114YS

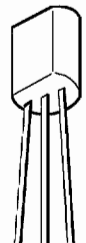

ECB  
2SA1296  
2SC1815  
2SD655

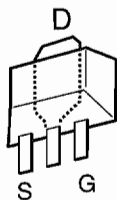

D  
S G  
2SJ278  
2SK1764



SGD  
2SK246

# PROTECTION OF EYES FROM LASER BEAM DURING SERVICING

This set employs laser. Therefore, be sure to follow carefully the instructions below when servicing.

## WARNING!

WHEN SERVICING, DO NOT APPROACH THE LASER EXIT WITH THE EYE TOO CLOSELY. IN CASE IT IS NECESSARY TO CONFIRM LASER BEAM EMISSION. BE SURE TO OBSERVE FROM A DISTANCE OF MORE THAN 30cm FROM THE SURFACE OF THE OBJECTIVE LENS ON THE OPTICAL PICK-UP BLOCK.

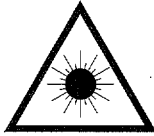

- Caution: Invisible laser radiation when open and interlocks defeated avoid exposure to beam.
- Advarsel: Usynlig laserstråling ved åbning, når sikkerhedsafbrydere er ude af funktion. Undgå udsættelse for stråling.

## VAROITUS!

Laiteen Käyttäminen muulla kuin tässä käyttöohjeessa mainituilla tavalla saattaa altistaa käyttäjän turvallisuusluokan 1 ylittävälle näkymättömälle lasersäteilylle.

## WARNING!

Om apparaten används på annat sätt än vad som specificeras i denna bruksanvisning, kan användaren utsättas för osynlig laserstråling, som överskrider gränsen för laserklass 1.

## CAUTION

Use of controls or adjustments or performance of procedures other than those specified herein may result in hazardous radiation exposure.

## ATTENTION

L'utilisation de commandes, réglages ou procédures autres que ceux spécifiés peut entraîner une dangereuse exposition aux radiations.

## ADVARSEL!

Usynlig laserstråling ved åbning, når sikkerhedsafbrydere er ude af funktion. Undgå udsættelse for stråling.

This Compact Disc player is classified as a CLASS 1 LASER product.

The CLASS 1 LASER PRODUCT label is located on the rear exterior.

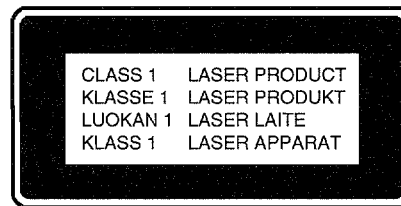

## Precaution to replace Optical block (KMS-194C)

Body or clothes electrostatic potential could ruin laser diode in the optical block. Be sure ground body and workbench, and use care the clothes do not touch the diode.

- 1) After the connection, remove solder shown in the right figure.

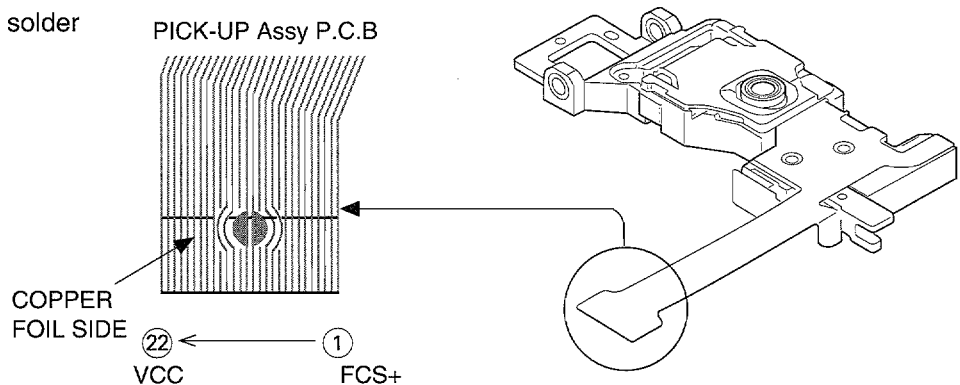

# MD DISASSEMBLY INSTRUCTIONS

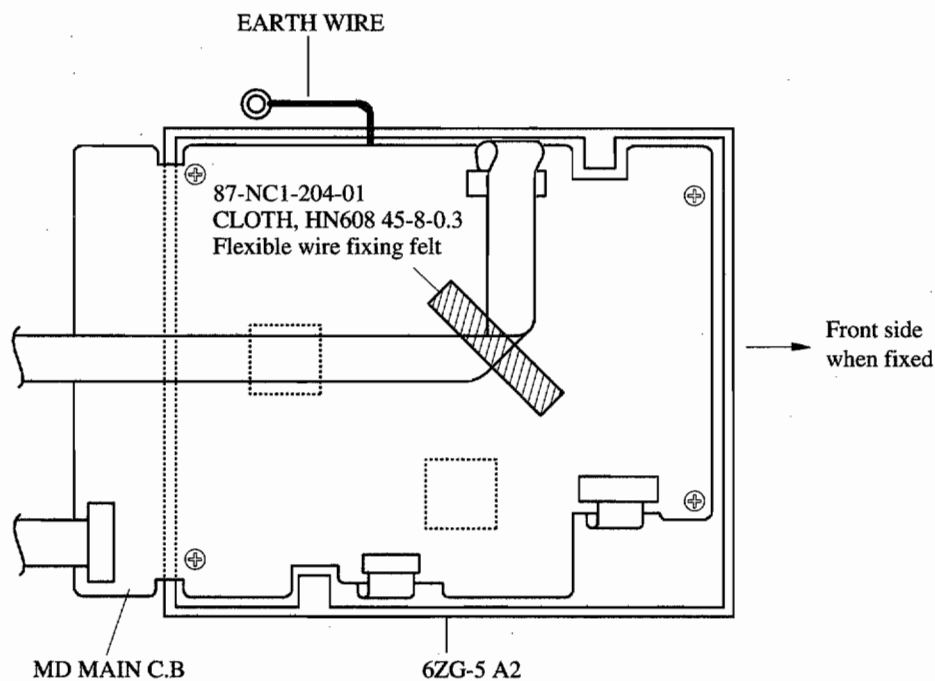

<BOTTOM VIEW>

## 1. Remove the HLDR, MD.

- 1) This MD mechanism uses the three types of spring. Be careful for the types of spring when attaching the HLDR, MD.

Spring (A): Black 10 turns

Spring (B): Silver 11 turns

Spring (C): Green 9 turns

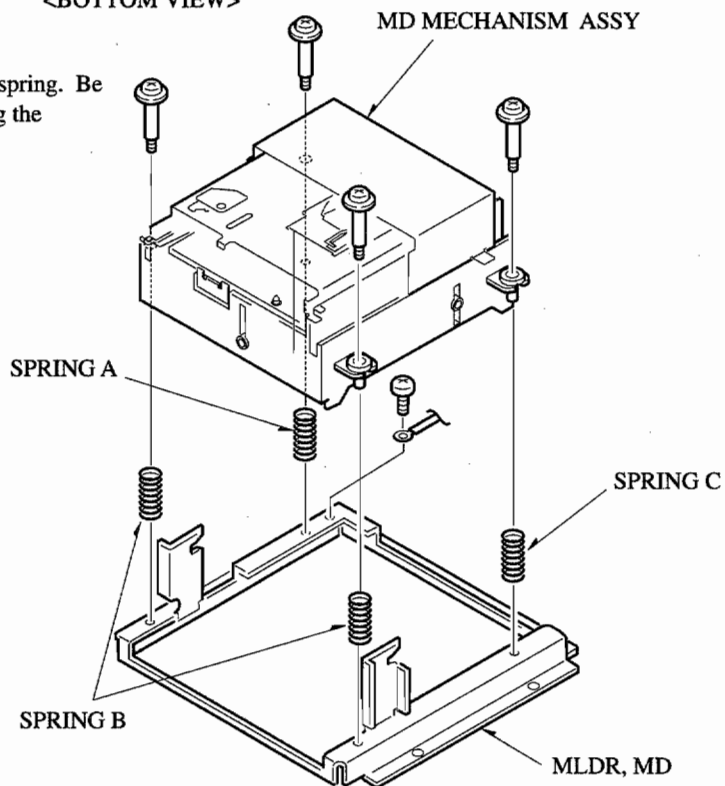

Fig-1

## 2. Remove the HOLD, RACK.

- 1) Rotate the GEAR, RELAY so that the HLDR, RACK moves to the PLAY position.
- 2) Deflect the hook (1) and pull out the HLDR, RACK in the direction of the arrow (2).

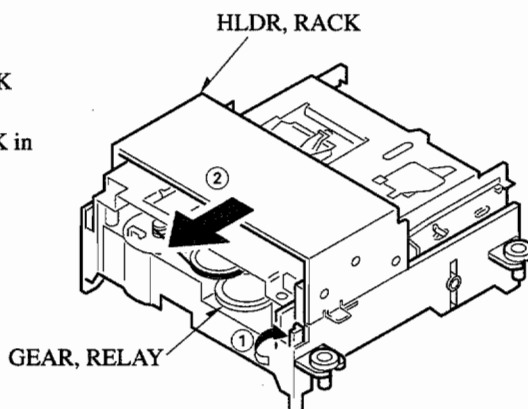

Fig-2

### 3. Remove the CHAS, LOADING ASSY.

- 1) Remove the two screws, connector and FLEX C.B.  
Remove the HDLR ASSY, LOADING.

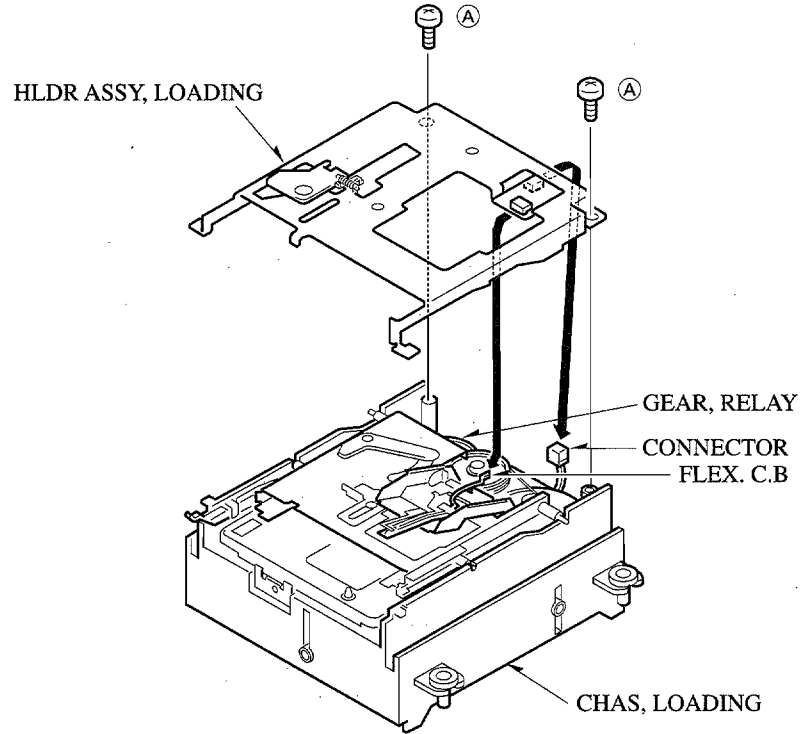

Fig-3

- 2) Confirm that the OWH has moved up. Then pull out the HDLR ASSY, CTRG in the direction of the arrow.

**Note:** Before starting this work confirm that the OWH (over-write head) has completely moved up. When the OWH is lowered, the HDLR ASSY, CTRG will be caught and the OWH will be bent.

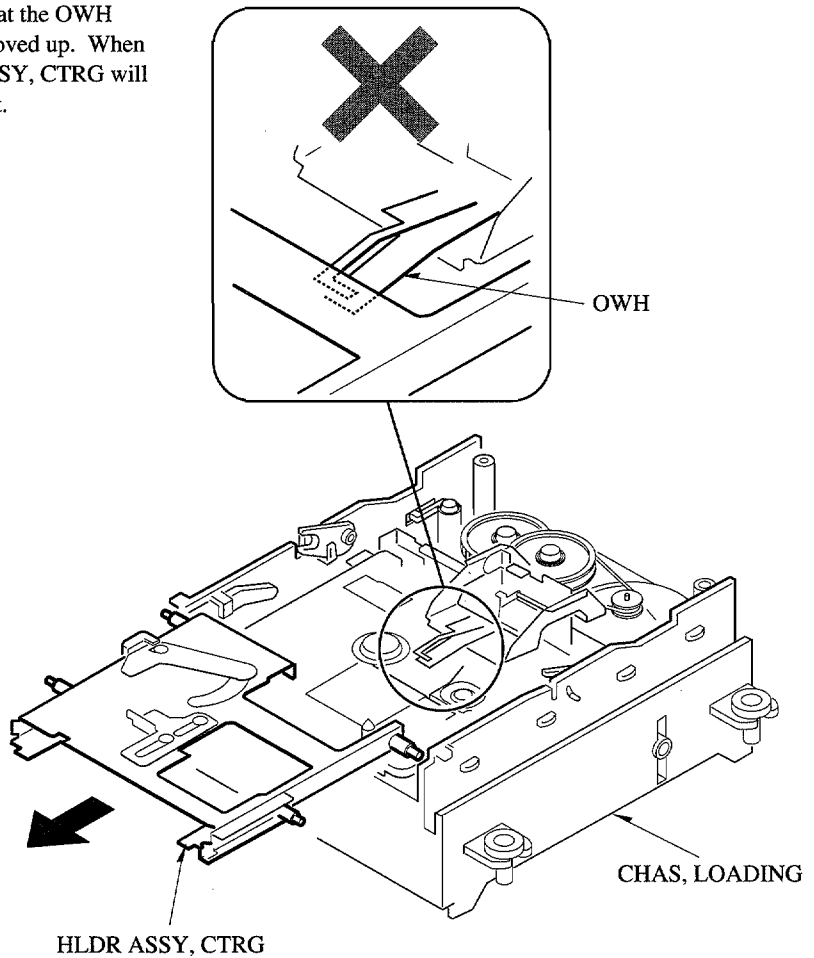

Fig-4

#### 4. Remove the MD mechanism.

- 1) Remove the two screws (A) and the screw (B), then remove the MD mechanism.

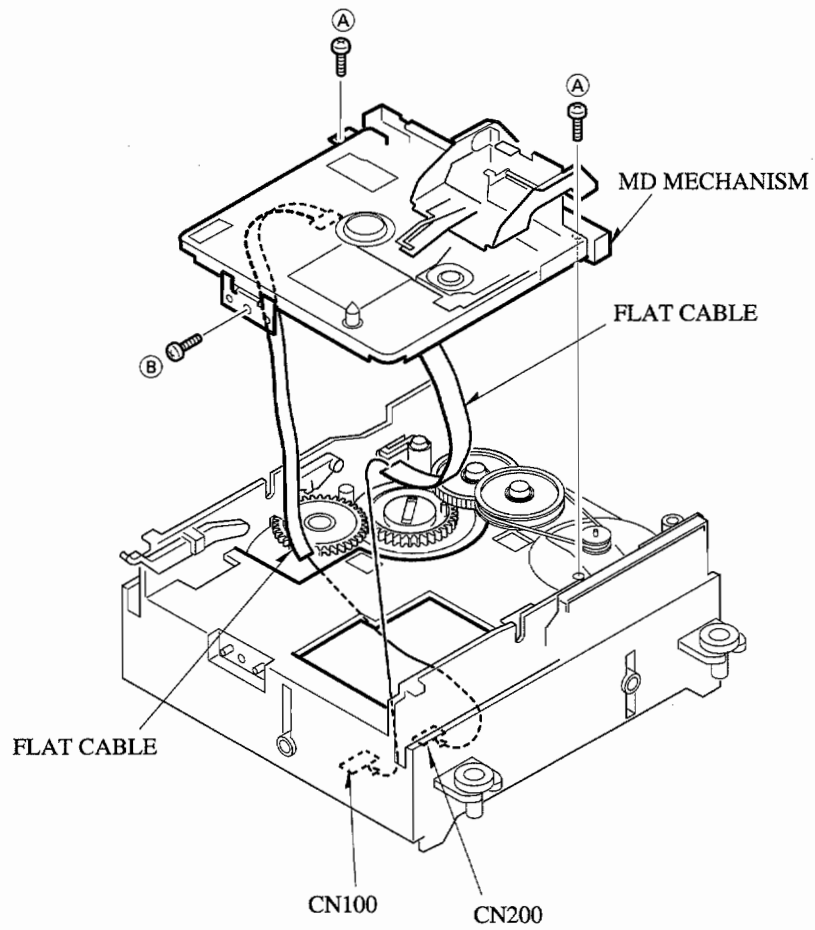
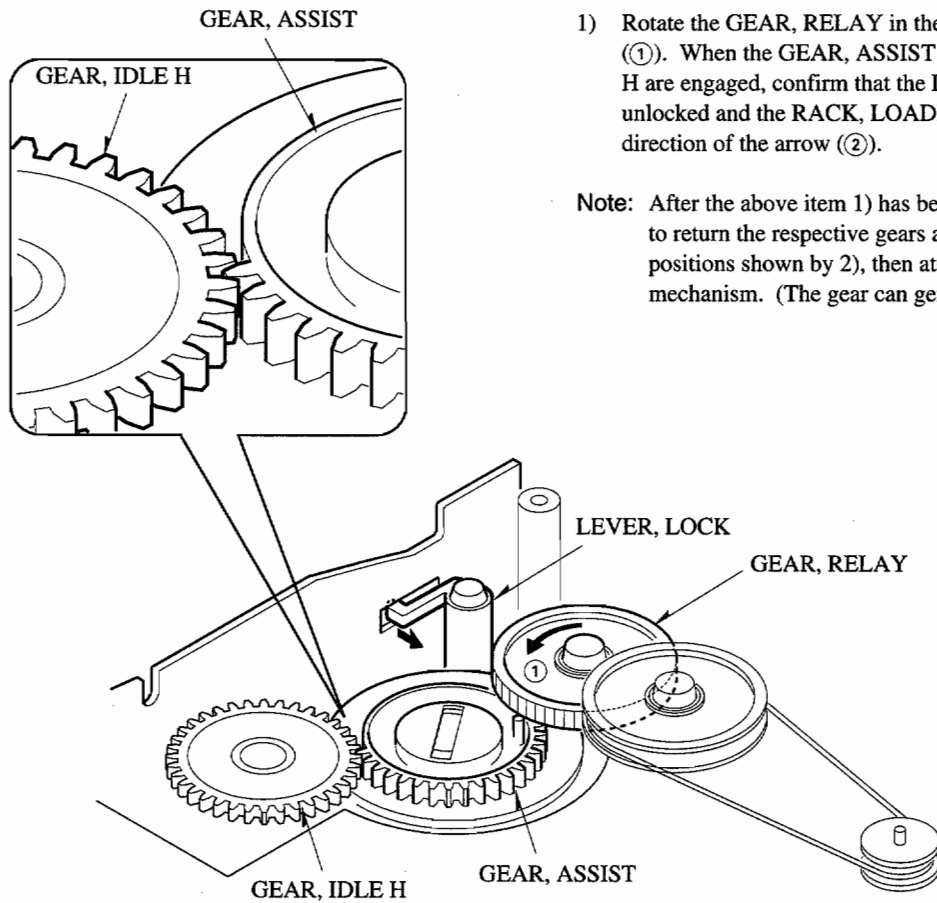

Fig-5

## 5. Gear and Lever Positions



- 1) Rotate the GEAR, RELAY in the direction of the arrow (①). When the GEAR, ASSIST and the GEAR, IDLE H are engaged, confirm that the LEVER, LOCK is unlocked and the RACK, LOADING L moves in the direction of the arrow (②).

**Note:** After the above item 1) has been confirmed, be sure to return the respective gears and levers to the positions shown by 2), then attach the MD mechanism. (The gear can generate the phase error.)

Fig-6

- 2) Confirm that the RACK, LOADING L is located at the loading end position, and the LEVER, LOCK locks the RACK, LOADING L when boss of the GEAR, ASSIST is located in the position as shown.

**Note:** When boss of the GEAR, ASSIST is positioned off the center in the direction of the arrow, EJECT cannot be performed. After the above item 2) has been confirmed, be sure to return the respective gears and levers to the positions as shown, then attach the MD mechanism. (The gear can generate the phase error.)

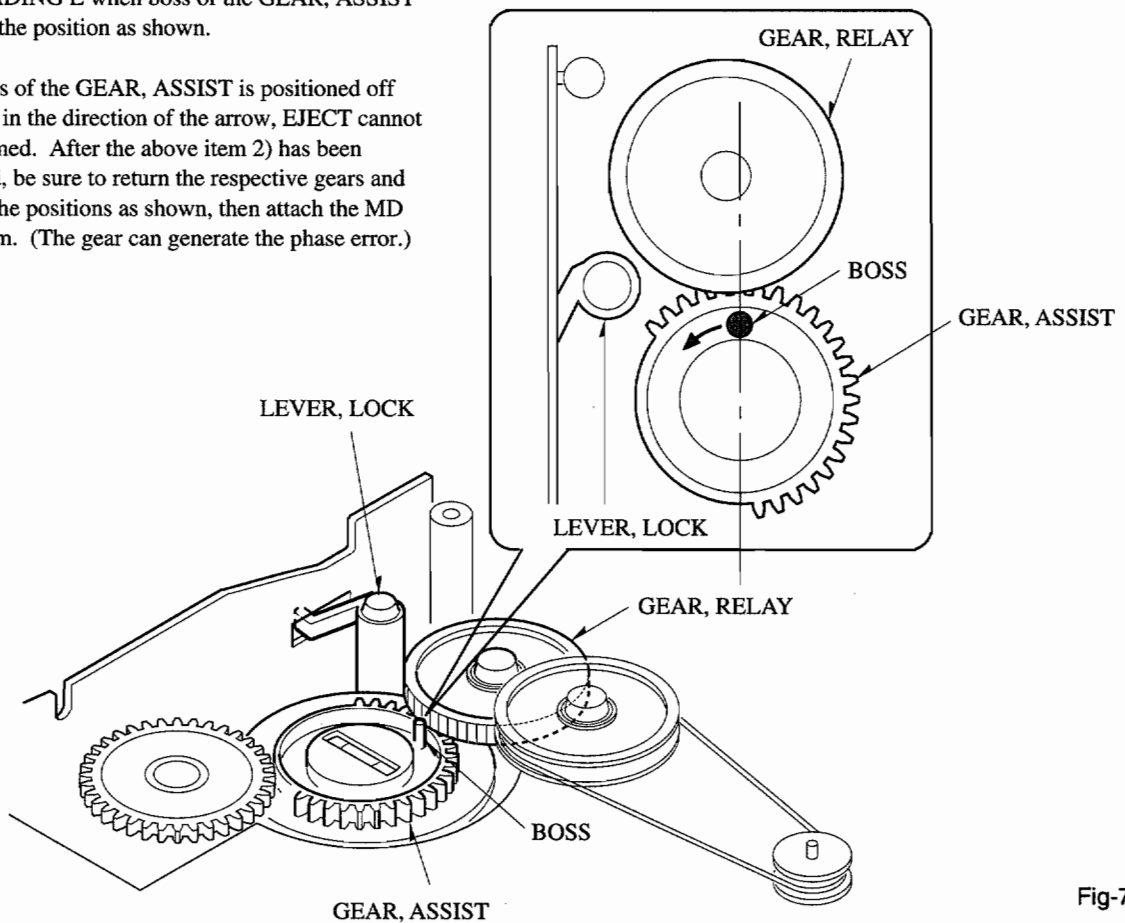

Fig-7



## 6. How to attach the MD mechanism

### 6-1. Gear and lever positions

- 1) Boss of the GEAR, ASSIST must face with the GEAR, RELAY when the boss is located at the center. When they are facing each other, confirm that the RACK, LOADING L is positioned at the loading end position and the LEVER, LOCK locks the RACK, LOADING L. (Refer to Fig-8.)

**Note:** When boss of the GEAR, ASSIST is positioned off the center in the direction of the arrow, EJECT cannot be performed.

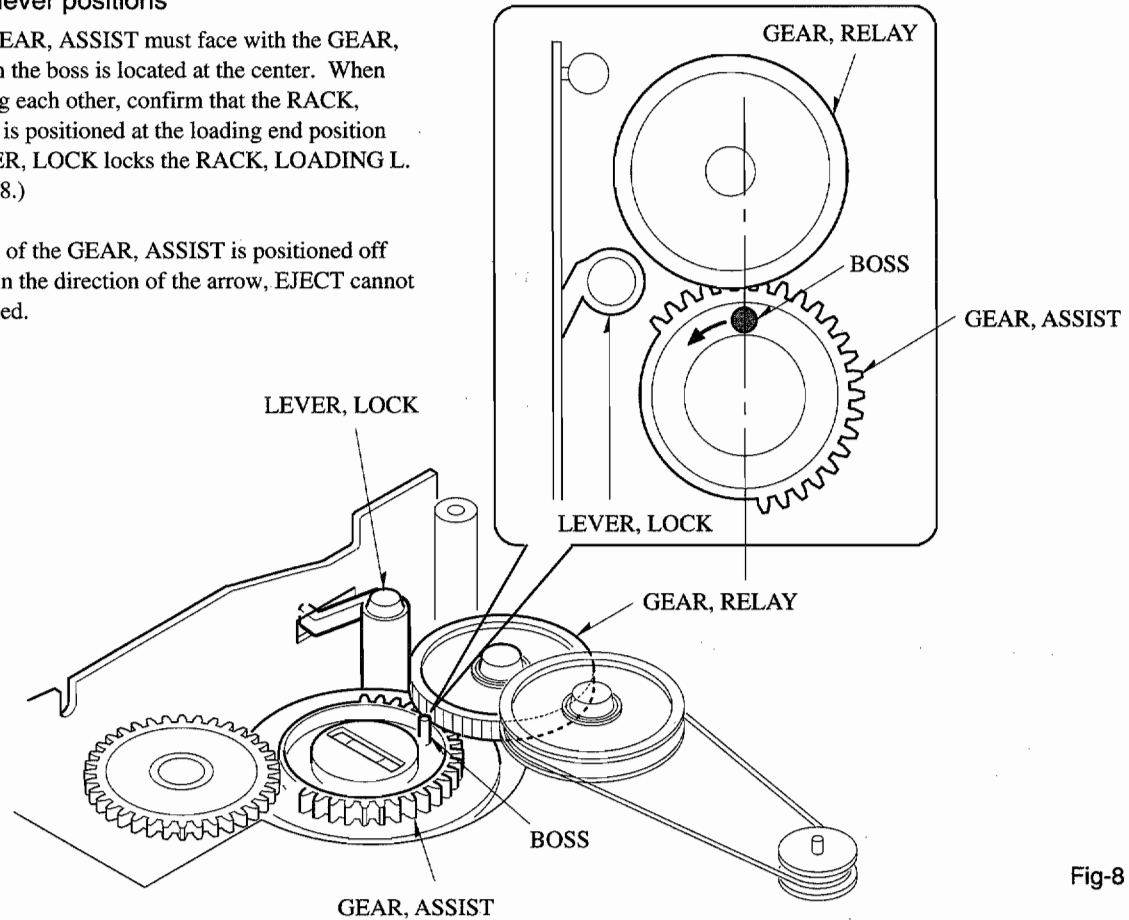
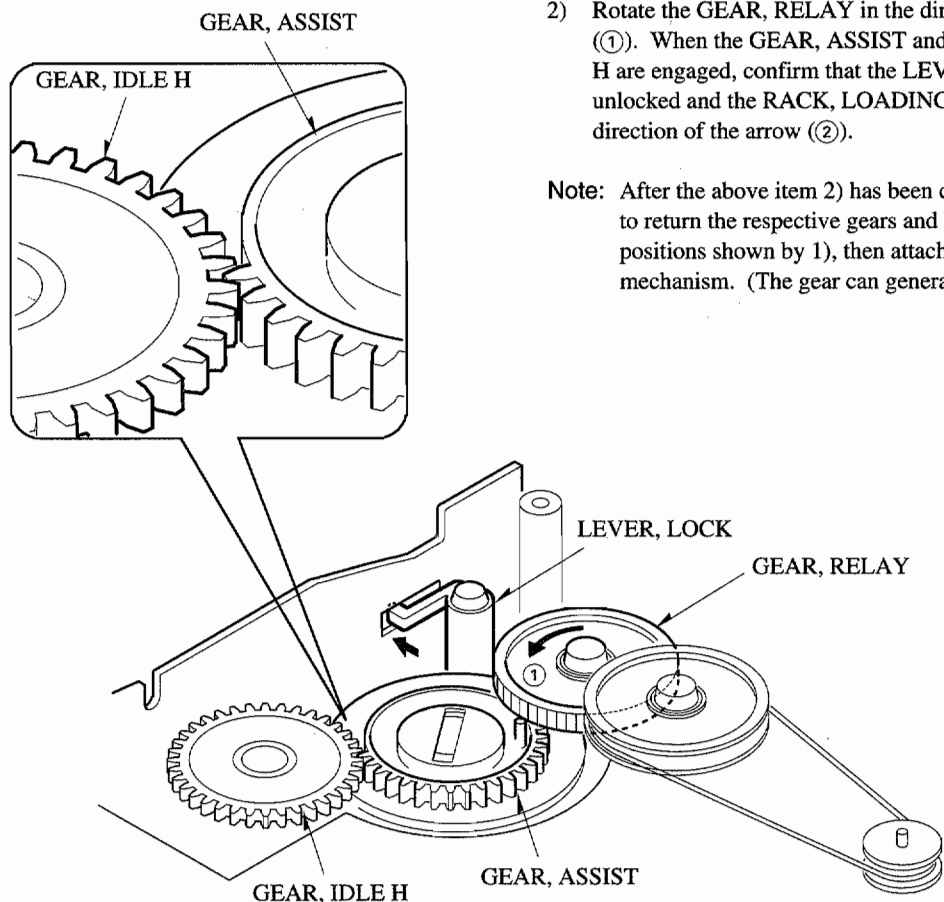

Fig-8



- 2) Rotate the GEAR, RELAY in the direction of the arrow (①). When the GEAR, ASSIST and the GEAR, IDLE H are engaged, confirm that the LEVER, LOCK is unlocked and the RACK, LOADING L moves in the direction of the arrow (②).

**Note:** After the above item 2) has been confirmed, be sure to return the respective gears and levers to the positions shown by 1), then attach the MD mechanism. (The gear can generate the phase error.)

Fig-9

- 3) Before attaching the MD mechanism, remove the SPR-T, LEV LOADING L/R from the boss of the LEVER, LOADING. (Refer to Fig-10.)
- 4) Attach the MD mechanism using two screws (A) and the screw (B).

**Note:** Be sure to route the two flat cables through the positions as shown.

- 5) Return the SPR-T, LVR LOADING L/R to the boss of the LEVER, LOADING. Place the arrow portion of the spring on top of the MD mechanism as shown.

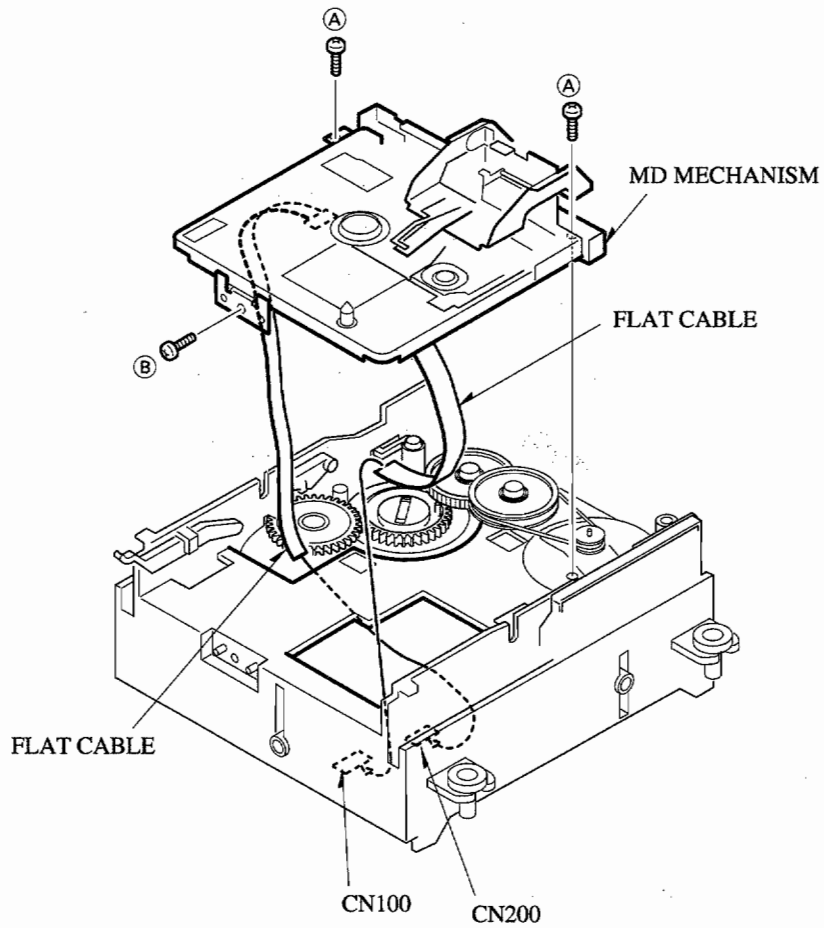

Fig-10

## 6-2. How to attach the CHAS, LOADING ASSY

(Refer to Fig-11.)

- 1) Confirm that the OWH has moved up. Then attach the HLDR ASSY, CTRG in the direction of the arrow.

**Note:** Before starting this work confirm that the OWH (over-write head) has completely moved up. When the OWH is lowered, the HLDR ASSY, CTRG will be caught and the OWH will be bent.

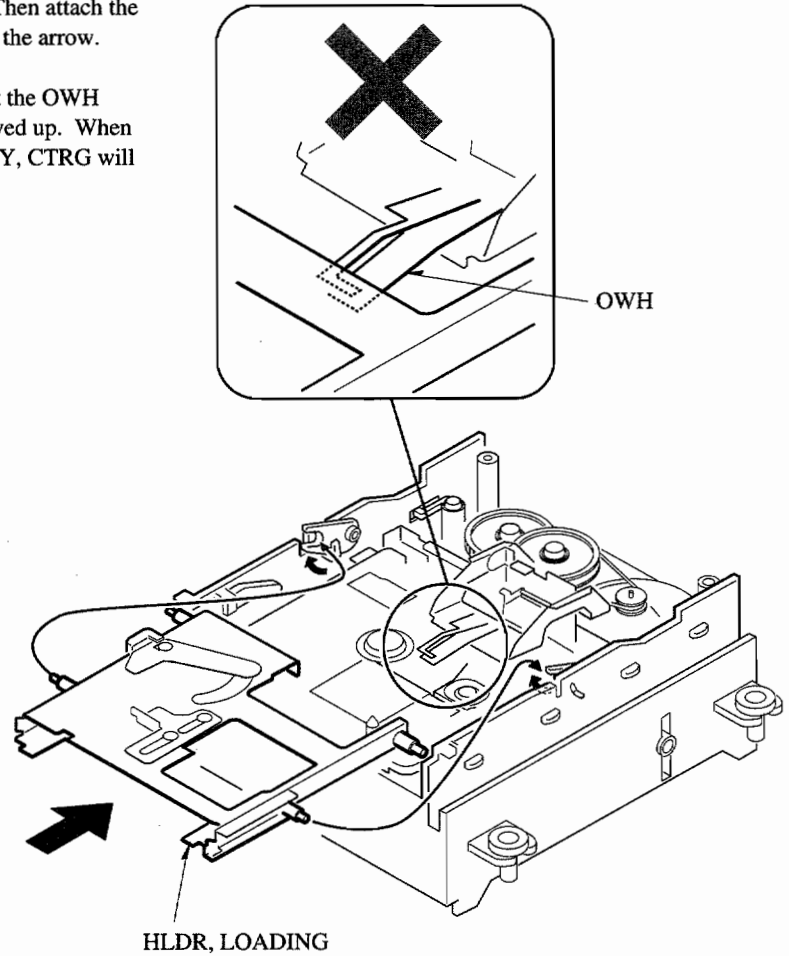

Fig-11

- 2) Attach HLDR ASSY, LOADING, insert the connector, FLEX C.B and fix them with two screws (A).

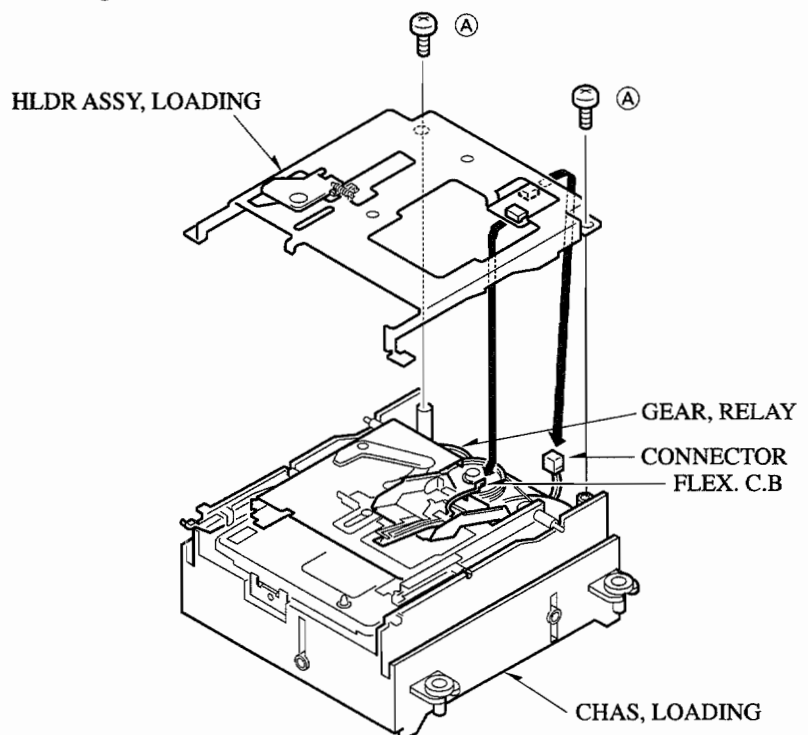

Fig-12

- 3) Deflect the hook (①) and attach the HLDR, RACK in the direction of the arrow.

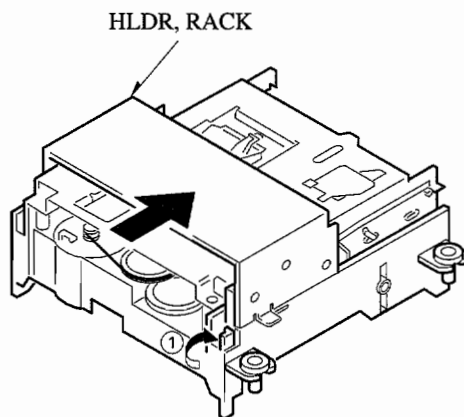

Fig-13

### 6-3. How to attach the HLDR, MD (Refer to Fig-14.)

- 1) This MD mechanism uses the three types of spring. Be careful for the types of spring when attaching the HLDR, MD.  
Spring A: Black 10 turns  
Spring B: Silver 11 turns  
Spring C: Green 9 turns

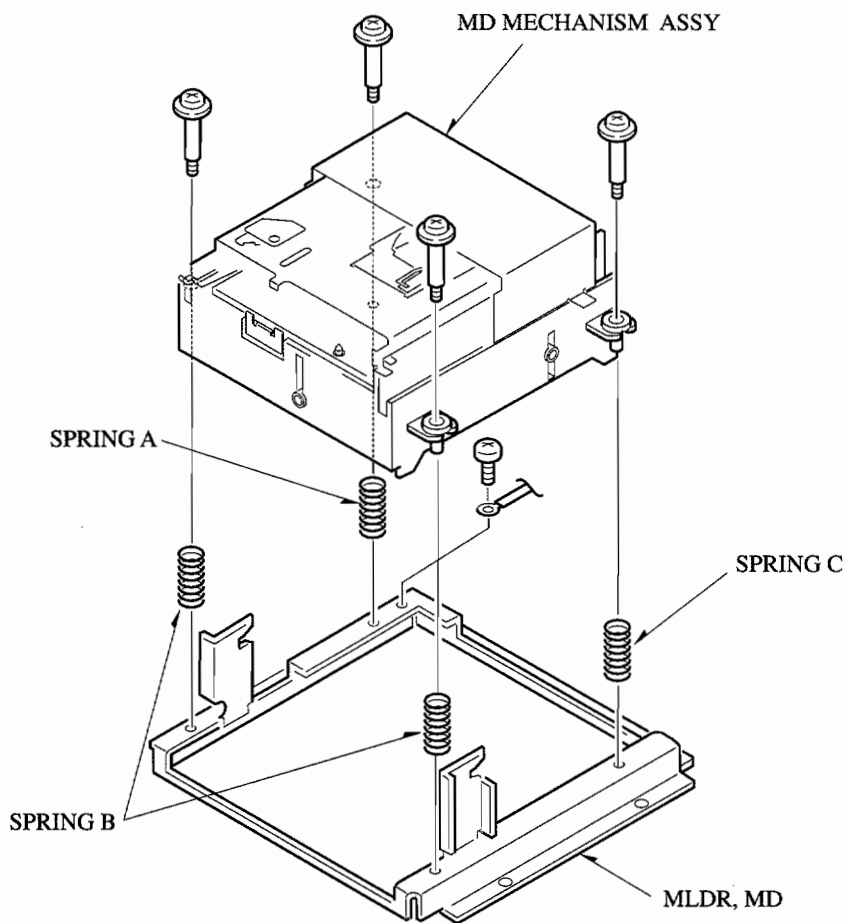

Fig-14

# ELECTRICAL MAIN PARTS LIST

DESCRIPTIONで判断できない物は "REFERENCE NAME LIST" を参照してください。  
If can't understand for Description please kindly refer to "REFERENCE NAME LIST".

REF. NO	PART NO.	KANRI NO.	DESCRIPTION	REF. NO	PART NO.	KANRI NO.	DESCRIPTION
IC				C127	87-010-405-080		CAP, E 10-50 SME 5X11
	87-001-982-010	IC, TA7291S		C128	87-010-405-080		CAP, E 10-50 SME 5X11
	87-A20-478-010	IC, M62414SP-700		C129	87-010-405-080		CAP, E 10-50 SME 5X11
	87-001-440-010	IC, BA15218N		△CN106	82-304-743-010		TERMINAL, 1P
	87-020-758-010	IC, NJM2068A		△CN107	82-304-743-010		TERMINAL, 1P
	87-001-583-080	IC, TC7S00F		△F101	87-A90-092-080		PROTECTOR, 2.5A 491SERIES 60V
	87-A20-014-010	C-IC, CXA1981Q/AR		FC1	88-911-201-110		FF-CABLE, 11P 1.25
	87-A20-397-010	C-IC, CXD2535CR-1		FC2	87-CC1-612-010		FF-CABLE, 16P 1.00 300MM
	87-A20-398-010	C-IC, CXD2536CR-1		FC3	87-NC1-615-010		FF-CABLE, 14P 1.00 250MM
	87-017-920-040	IC, HM51W4400BS/BLS78		L100	87-030-274-010		FLTR, LINE LF-4D-333
	86-CD0-601-010	C-IC, CXP81952		FRONT C.B			
	87-A20-496-040	C-IC, MPC17A38ZVMEL		C902	87-010-197-080		C-CAP, S 0.01-25 K B
	87-017-360-080	IC, SC7S04F		C904	87-A10-189-040		CAP, E 220-10
	87-001-881-080	IC, TC7SU04F		C905	87-A10-189-040		CAP, E 220-10
	87-002-465-080	IC, TC74HC368AF		C906	87-A10-189-040		CAP, E 220-10
	87-017-984-080	IC, TK11230		C907	87-010-071-080		CAP, E 1-50 M 5L SRE
	87-A20-698-010	C-IC, AK4512VF		C908	87-010-498-040		CAP, E 10-16 GAS
	87-NC1-618-010	C-IC, M38198MC-107FP		C910	87-012-140-080		C-CAP, S 470P-50 J CH GRM
	84-HM1-622-040	IC, CXA8027N		C911	87-012-140-080		C-CAP, S 470P-50 J CH GRM
	87-A90-549-010	RCR UNIT, SPS-440-1		C912	87-012-140-080		C-CAP, S 470P-50 J CH GRM
	87-017-915-080	C-IC, BU4094BCF		C913	87-012-140-080		C-CAP, S 470P-50 J CH GRM
TRANSISTOR				C914	87-012-140-080		C-CAP, S 470P-50 J CH GRM
	89-112-965-080	TR, 2SA1296GR		C915	87-012-156-080		C-CAP, S 220P-50 J CH GRM
	87-026-462-080	TR, 2SC1740SRS		C916	87-012-156-080		C-CAP, S 220P-50 J CH GRM
	89-213-702-010	TR, 2SB1370E		C917	87-012-156-080		C-CAP, S 220P-50 J CH GRM
	89-502-465-080	FET, 2SK246GR		C918	87-012-156-080		C-CAP, S 220P-50 J CH GRM
	89-318-155-080	TR, 2SC1815GR		C919	87-012-156-080		C-CAP, S 220P-50 J CH GRM
	87-026-215-080	TR, DTC114YS		C920	87-012-156-080		C-CAP, S 220P-50 J CH GRM
	87-026-483-080	TR, DTA123JS (TP)		C921	87-012-156-080		C-CAP, S 220P-50 J CH GRM
	89-406-555-080	TR, 2SD655E		C922	87-012-156-080		C-CAP, S 220P-50 J CH GRM
	87-026-423-080	C-TR RN2305		C923	87-012-156-080		C-CAP, S 220P-50 J CH GRM
	89-341-165-080	CHIP TRANSISTOR 2SC4116GR		C924	87-012-156-080		C-CAP, S 220P-50 J CH GRM
	89-115-884-080	CHIP -TRANSISTER 2SA1588Y		C925	87-012-156-080		C-CAP, S 220P-50 J CH GRM
	89-112-134-080	C-TR, 2SA1213Y		C926	87-010-322-080		C-CAP, S 100P-50 J CH
	87-A30-056-080	C-PET, 2SJ278		C927	87-010-322-080		C-CAP, S 100P-50 J CH
	87-A30-057-080	C-PET, 2SK1764		C928	87-010-178-080		C-CAP, S 1000P-50 K B
	87-026-235-080	C-TR, DTC114EK		C929	87-010-322-080		C-CAP, S 100P-50 J CH
	87-026-227-080	CHIP-TR, DTA114EK		C930	87-010-178-080		C-CAP, S 1000P-50 K B
				C931	87-010-178-080		C-CAP, S 1000P-50 K B
				C934	87-010-197-080		C-CAP, S 0.01-25 K B
				C935	87-010-498-040		CAP, E 10-16 GAS
DIODE				C936	87-010-189-080		C-CAP, S 8200P-50 K B
	87-017-978-080	DIODE, 1N4003		C937	87-010-189-080		C-CAP, S 8200P-50 K B
	87-A40-244-080	ZENER, M7ZJ T-72 7.5B		C938	87-A10-189-040		CAP, E 220-10
	87-A40-383-080	ZENER, M7ZJ30A		C940	87-010-313-080		C-CAP, S 18P-50 J CH
	87-020-465-080	DIODE, 1SS133		C941	87-010-312-080		C-CAP, S 15P-50 J CH
	87-017-850-080	C-DIODE, DAP222		C950	87-010-197-080		C-CAP, S 0.01-25 K B
	87-A40-124-080	C-DIODE, RB501V-40		C951	87-010-197-080		C-CAP, S 0.01-25 K B
	87-020-575-080	C-ZENER, 02CZ2.4Z		C952	87-010-196-080		C-CAP, S 0.1-25 Z F
	87-017-948-080	C-DIODE, U1FWJ44N		FL901	87-CC1-608-010		FL, 7CC-1
	87-002-419-080	C-DIODE, U1BC44		J101	87-099-389-010		JACK, 3.5 ST BLK
	87-020-027-080	C-DIODE, 1SS184		L901	87-005-485-080		COIL, 100UH J FLR50
MAIN C.B				LED907	87-A40-380-080		LED, SEL6510C-TP5 GRN
C110	87-015-997-010	CAP, E 2200-16 M SME		LED908	87-A40-380-080		LED, SEL6510C-TP5 GRN
C111	87-010-940-010	CAP, E 0.01F-16 M		LED909	87-A40-373-080		LED, SEL2510C-TP1
C112	87-010-247-080	CAP, E 100-50 SME		LED910	87-A40-373-080		LED, SEL2510C-TP1
C113	87-010-405-080	CAP, E 10-50 SME 5X11		LED911	87-A40-380-080		LED, SEL6510C-TP5 GRN
C114	87-010-248-080	CAP, E 220-10 SME 6X11		SW901	87-A90-085-010		SW, RTRY EC16B 24204
C115	87-010-197-080	C-CAP, S 0.01-25 K B		SW902	87-036-215-080		SW, TACT EVQ 214 04M
C116	87-010-405-080	CAP, E 10-50 SME 5X11		SW903	87-036-215-080		SW, TACT EVQ 214 04M
C117	87-010-252-080	CAP, ELECT 1000-6.3V		SW905	87-036-215-080		SW, TACT EVQ 214 04M
C120	87-010-405-080	CAP, E 10-50 SME 5X11		SW906	87-036-215-080		SW, TACT EVQ 214 04M
C121	87-010-401-080	CAP, E 1-50 SME 5X11		SW907	87-036-215-080		SW, TACT EVQ 214 04M
C122	87-010-247-080	CAP, E 100-50 SME		SW908	87-036-215-080		SW, TACT EVQ 214 04M
C123	87-010-248-080	CAP, E 220-10 SME 6X11		SW909	87-036-215-080		SW, TACT EVQ 214 04M
C124	87-010-401-080	CAP, E 1-50 SME 5X11		SW910	87-036-215-080		SW, TACT EVQ 214 04M
C125	87-010-248-080	CAP, E 220-10 SME 6X11		SW911	87-036-215-080		SW, TACT EVQ 214 04M
				SW912	87-036-215-080		SW, TACT EVQ 214 04M

REF. NO	PART NO.	KANRI NO.	DESCRIPTION	REF. NO	PART NO.	KANRI NO.	DESCRIPTION
SW913	87-036-215-080		SW,TACT EVQ 214 04M	C710	87-016-462-080		C-CAP,S 1-16 Z F
SW979	87-036-215-080		SW,TACT EVQ 214 04M	C711	87-A10-025-080		C-CAP,U 0.22-16Z F
X901	87-008-497-080		CERA LOCK CST7.68MTW	C712	87-016-462-080		C-CAP,S 1-16 Z F
X902	87-030-273-010		VIB,XTAL 32.768KHZ DT-38 5PPM	C713	87-012-284-080		CAP, U 6800P-50
				C714	87-012-276-080		CAP, CHIP SS 1500 PBK
JACK C.B				C715	87-010-829-080		CAP, U 0.047-16
C200	87-010-196-080		C-CAP,S 0.1-25 Z F	C716	87-010-662-080		C-CAP,E 22-6.3
C201	87-010-248-080		CAP,E 220-10 SME 6X11	C717	87-012-286-080		CAP, U 0.01-25
C202	87-010-248-080		CAP,E 220-10 SME 6X11	C718	87-012-195-080		C-CAP,U 100P-50CH
C203	87-010-911-080		CAP,E 10-50 ASF	C719	87-012-286-080		CAP, U 0.01-25
C204	87-010-911-080		CAP,E 10-50 ASF	C720	87-016-436-080		C-CAP,TN 47-4(B2)
C205	87-012-156-080		C-CAP,S 220P-50 J CH GRM	C721	87-010-662-080		C-CAP,E 22-6.3
C206	87-012-156-080		C-CAP,S 220P-50 J CH GRM	C722	87-010-787-080		CAP, U 0.022-25
C207	87-010-181-080		C-CAP,S 1800P-50 K B	C723	87-010-829-080		CAP, U 0.047-16
C208	87-010-181-080		C-CAP,S 1800P-50 K B	C724	87-010-662-080		C-CAP,E 22-6.3
C211	87-012-156-080		C-CAP,S 220P-50 J CH GRM	C725	87-010-662-080		C-CAP,E 22-6.3
C212	87-012-156-080		C-CAP,S 220P-50 J CH GRM	C726	87-010-831-080		C-CAP,U 0.1-16 Z F
C213	87-010-911-080		CAP,E 10-50 ASF	C727	87-016-462-080		C-CAP,S 1-16 Z F
C214	87-010-911-080		CAP,E 10-50 ASF	C728	87-012-276-080		CAP, CHIP SS 1500 PBK
C215	87-010-248-080		CAP,E 220-10 SME 6X11	C730	87-012-196-080		C-CAP,U 120P-50 CH
C216	87-010-248-080		CAP,E 220-10 SME 6X11	C731	87-010-787-080		CAP, U 0.022-25
C221	87-010-318-080		C-CAP,S 47P-50 J CH	C732	87-016-462-080		C-CAP,S 1-16 Z F
C222	87-010-318-080		C-CAP,S 47P-50 J CH	C733	87-012-286-080		CAP, U 0.01-25
C223	87-010-405-080		CAP,E 10-50 SME 5X11	C734	87-010-831-080		C-CAP,U 0.1-16 Z F
C224	87-010-405-080		CAP,E 10-50 SME 5X11	C735	87-012-195-080		C-CAP,U 100P-50CH
C232	87-010-197-080		C-CAP,S 0.01-25 K B	C736	87-012-279-080		C-CAP,U 2700P-50 B
C233	87-010-263-080		CAP,E 100-10 SME 5X11	C737	87-016-462-080		C-CAP,S 1-16 Z F
C234	87-010-405-080		CAP,E 10-50 SME 5X11	C738	87-010-831-080		C-CAP,U 0.1-16 Z F
C235	87-010-405-080		CAP,E 10-50 SME 5X11	C739	87-012-166-080		C-CAP,U 4P-50 CH
C236	87-010-405-080		CAP,E 10-50 SME 5X11	C740	87-012-166-080		C-CAP,U 4P-50 CH
C237	87-010-405-080		CAP,E 10-50 SME 5X11	C741	87-010-831-080		C-CAP,U 0.1-16 Z F
C238	87-010-405-080		CAP,E 10-50 SME 5X11	C743	87-010-662-080		C-CAP,E 22-6.3
C239	87-010-263-080		CAP,E 100-10 SME 5X11	C744	87-A10-057-080		C-CAP,TN 100-4 F95 E
C240	87-010-193-080		C-CAP,S 0.033-25 K F	C746	87-010-831-080		C-CAP,U 0.1-16 Z F
C241	87-010-178-080		C-CAP,S 1000P-50 K B	C747	87-016-462-080		C-CAP,S 1-16 Z F
C242	87-010-178-080		C-CAP,S 1000P-50 K B	C749	87-010-252-010		CAP,ELECT 1000-6.3V
C243	87-010-405-080		CAP,E 10-50 SME 5X11	C750	87-010-464-080		CAP ELECT 220-4
C244	87-010-405-080		CAP,E 10-50 SME 5X11	C751	87-010-252-010		CAP,ELECT 1000-6.3V
C245	87-010-197-080		C-CAP,S 0.01-25 K B	C752	87-010-464-080		CAP ELECT 220-4
C246	87-010-196-080		C-CAP,S 0.1-25 Z F	C753	87-010-779-080		C-CAP,E 100-6.3
C247	87-010-805-080		C-CAP,S 1-16 Z F	C754	87-016-462-080		C-CAP,S 1-16 Z F
C248	87-010-405-080		CAP,E 10-50 SME 5X11	C755	87-010-831-080		C-CAP,U 0.1-16 Z F
C249	87-010-196-080		C-CAP,S 0.1-25 Z F	C756	87-A10-514-010		CAP,AS 22-10 OSFA
C250	87-010-805-080		C-CAP,S 1-16 Z F	C757	87-010-875-080		C-CAP,1000P-500 K W5R
C252	87-010-197-080		C-CAP,S 0.01-25 K B	C758	87-010-831-080		C-CAP,U 0.1-16 Z F
C253	87-010-197-080		C-CAP,S 0.01-25 K B	C759	87-010-831-080		C-CAP,U 0.1-16 Z F
J201	87-A20-625-010		IC,RX178A	C761	87-016-462-080		C-CAP,S 1-16 Z F
J202	87-017-825-010		IC,GP1F32T	C762	87-016-462-080		C-CAP,S 1-16 Z F
J203	87-009-394-010		JACK PIN, 4P EARTH	C763	87-010-831-080		C-CAP,U 0.1-16 Z F
L201	87-003-149-080		COIL,47UH K LAL02	C764	87-010-831-080		C-CAP,U 0.1-16 Z F
L202	87-003-149-080		COIL,47UH K LAL02	C766	87-010-831-080		C-CAP,U 0.1-16 Z F
L203	87-008-501-080		FLTR,DSS306-B101	C767	87-010-779-080		C-CAP,E 100-6.3
L204	87-008-501-080		FLTR,DSS306-B101	C768	87-010-662-080		C-CAP,E 22-6.3
L205	87-003-291-080		FLTR,EMI DSS306 102M	C769	87-010-464-080		CAP ELECT 220-4
L206	87-003-291-080		FLTR,EMI DSS306 102M	C788	87-010-831-080		C-CAP,U 0.1-16 Z F
L299	87-003-149-080		COIL,47UH K LAL02	C789	87-010-831-080		C-CAP,U 0.1-16 Z F
MD MAIN C.B				C790	87-012-274-080		C-CAP,U 1000P-50 K B
C700	87-012-286-080		CAP, U 0.01-25	C791	87-012-274-080		C-CAP,U 1000P-50 K B
C701	87-016-462-080		C-CAP,S 1-16 Z F	C798	87-012-195-080		C-CAP,U 100P-50CH
C702	87-012-286-080		CAP, U 0.01-25	C828	87-010-662-080		C-CAP,E 22-6.3
C703	87-012-274-080		C-CAP,U 1000P-50 K B	C834	87-010-657-080		C-CAP,E 1-50
C704	87-010-787-080		CAP, U 0.022-25	C835	87-010-662-080		C-CAP,E 22-6.3
C705	87-010-662-080		C-CAP,E 22-6.3	C836	87-012-286-080		CAP, U 0.01-25
C706	87-010-662-080		C-CAP,E 22-6.3	C851	87-010-662-080		C-CAP,E 22-6.3
C707	87-A10-025-080		C-CAP,U 0.22-16Z F	C852	87-010-662-080		C-CAP,E 22-6.3
C708	87-016-460-080		C-CAP,S 0.22-16 K B	C853	87-010-831-080		C-CAP,U 0.1-16 Z F
C709	87-010-829-080		CAP, U 0.047-16	C854	87-010-831-080		C-CAP,U 0.1-16 Z F
				C855	87-012-278-080		C-CAP,U 2200P-50 K B
				C856	87-012-278-080		C-CAP,U 2200P-50 K B
				C857	87-010-661-080		C-CAP,E 10-16

REF. NO	PART NO.	KANRI NO.	DESCRIPTION
C858	87-010-661-080		C-CAP, E 10-16
C859	87-010-831-080		C-CAP, U 0.1-16 Z F
C860	87-010-831-080		C-CAP, U 0.1-16 Z F
C861	87-010-831-080		C-CAP, U 0.1-16 Z F
C862	87-010-662-080		C-CAP, E 22-6.3
C863	87-010-662-080		C-CAP, E 22-6.3
C864	87-010-831-080		C-CAP, U 0.1-16 Z F
C865	87-010-662-080		C-CAP, E 22-6.3
CN706	87-099-440-080		C-CONN, 2P ZR-SM3 WHT
D702	87-017-925-070		C-VART-CAP, KV1460
FC5	86-ZG2-617-010		FF-CABLE, 11P 0.5 125
L701	87-A50-010-080		C-COIL, 22UH LQH3C
L702	87-A50-012-080		C-COIL, 100UH LQH3C
L703	87-A50-117-080		C-COIL, 10UHLQH3C
L704	87-A50-117-080		C-COIL, 10UHLQH3C
L705	87-A50-010-080		C-COIL, 22UH LQH3C
L706	87-005-777-080		C-COIL, 1UK NL25
L707	87-A50-013-080		C-COIL, 560UH LQH3C
L708	87-A50-013-080		C-COIL, 560UH LQH3C
L709	87-A50-012-080		C-COIL, 100UH LQH3C
L710	84-HD1-618-080		C-COIL, 33UH
L711	84-HD1-618-080		C-COIL, 33UH
L712	87-005-778-080		C-COIL, 10UK NLC25
L713	84-HD1-618-080		C-COIL, 33UH
L715	87-A50-117-080		C-COIL, 10UHLQH3C
L801	87-A50-116-080		C-COIL, 4.7UHLQH3C
R748	87-022-223-080		CHIP RES 2.2K 1/16W F
R749	87-022-239-080		C-RES U 10K-1/16WF
R752	87-022-231-080		C-RES, U 4.7K-1/16W F
R753	87-022-239-080		C-RES U 10K-1/16WF
R756	87-022-227-080		C-RES, U 3.3K-1/16W F
R757	87-022-239-080		C-RES U 10K-1/16WF
VR701	87-024-411-080		C-SFR, 47K RHO3A3A
VR702	87-024-401-080		CHIP SFR 1K RHO3A3A
VR703	87-024-409-080		C-SFR, 22K RHO3A3A
X701	87-A70-048-010		VIB, 45.1584MHZ
X702	87-030-369-080		C-VIB, CER PBRC12.00B

REF. NO	PART NO.	KANRI NO.	DESCRIPTION
DRV C.B			
C901	87-A10-019-080		C-CAP, TN 10-6.3 A
C902	87-010-787-080		CAP, U 0.022-25
C903	87-010-787-080		CAP, U 0.022-25
C904	87-010-829-080		CAP, U 0.047-16
C905	87-012-274-080		C-CAP, U 1000P-50 K B
C906	87-012-274-080		C-CAP, U 1000P-50 K B
C907	87-012-274-080		C-CAP, U 1000P-50 K B
C908	87-010-831-080		C-CAP, U 0.1-16 Z F
C909	87-010-831-080		C-CAP, U 0.1-16 Z F
C910	87-012-280-080		CAP, U 3300P-50
C911	87-016-462-080		C-CAP, S 1-16 Z F
FC6	86-ZG2-618-010		FF-CABLE, 4P 2 20MM
L901	87-A50-010-080		C-COIL, 22UH LQH3C
SW901	87-036-269-080		SW, PUCH ESEL02MH1
SW902	87-036-350-080		C-SW, PUSH SPPW9-4.8
SW903	87-036-366-080		C-SW, PUSH SPPW9-5.45
MOTOR C.B			
C1	87-010-263-080		CAP, E 100-10 SME 5X11
C3	87-018-209-080		CAP, TC U 0.1-50 Z F UP050
FC4	86-CD0-614-010		FF-CABLE, 8P 1.25 30MM
M1	87-045-305-010		MOT, RF-500TB
PH1	87-026-573-010		SNSR, PHOTO GP1S53
OWH C.B			
CN903	87-099-440-080		C-CONN, 2P ZR-SM3 WHT
SW C.B			
SW1	87-A90-117-010		SW, PUSH 1-1-1 MPU103
SW2	87-A90-117-010		SW, PUSH 1-1-1 MPU103

○ チップ抵抗部品コード / CHIP RESISTOR PART CODE

チップ抵抗部品コードの成り立ち  
Chip Resistor Part Coding

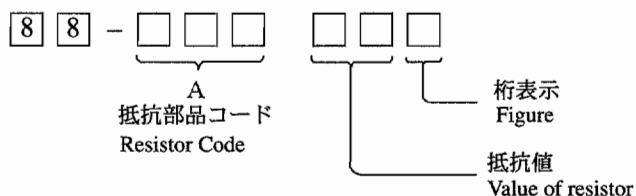

チップ抵抗  
Chip resistor

容量 Wattage	種類 Type	許容誤差 Tolerance	記号 Symbol	寸法 / Dimensions (mm)			抵抗コード : A Resistor Code : A	
				外形 / Form	L	W		t
1/16W	1608	5%	CJ		1.6	0.8	0.45	108
1/10W	2125	5%	CJ		2	1.25	0.45	118
1/8W	3216	5%	CJ		3.2	1.6	0.55	128

## WAVE FORM

### [ LED Display ]

- ① IC901 Pin ①① (LLATCH) VOLT/DIV: 5V  
TIME/DIV: 20μS
- ② IC901 Pin ①③ (LCLK)
- ③ IC901 Pin ①② (LDATA)

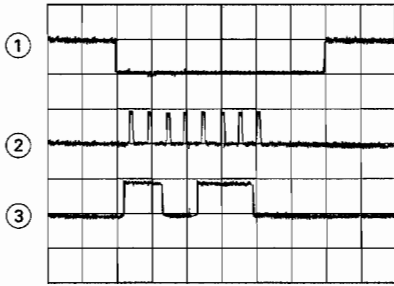

### [ REC VR Data transfer ]

- ④ IC901 Pin ①⑦ (RDT) VOLT/DIV: 5V  
TIME/DIV: 100μS
- ⑤ IC901 Pin ①⑥ (RCLK)

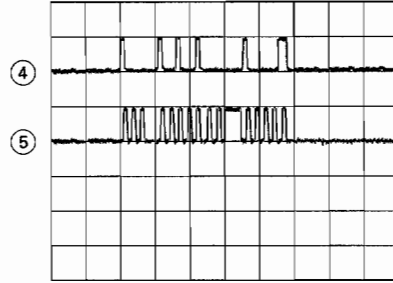

### [ Loading SW ]

- ⑥ IC901 Pin ④ (PB SW) VOLT/DIV: 5V  
TIME/DIV: 200mS
- ⑦ IC901 Pin ⑤ (REC SW)
- ⑧ IC901 Pin ③ (LD SW)

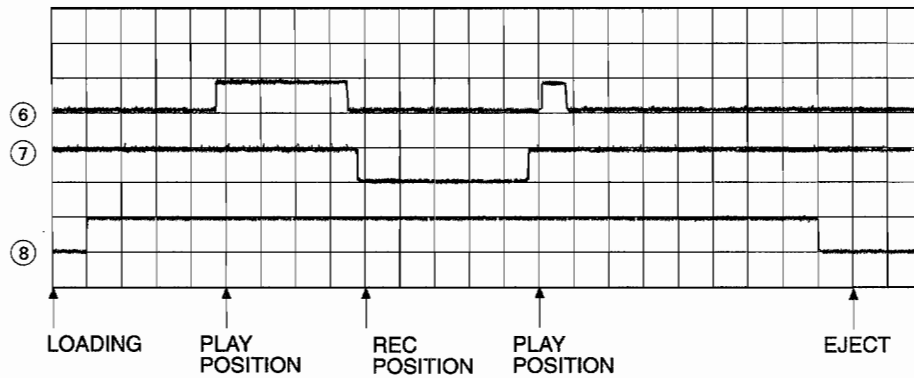

### [ Put AC from ZERO CHARGE ]

- ⑨ IC901 Pin ⑨① (VCC) VOLT/DIV: 5V  
TIME/DIV: 500mS
- ⑩ IC901 Pin ④①① (AVREF)
- ⑪ IC901 Pin ③④ (AC OFF)
- ⑫ IC901 Pin ③⑤ (RESET)

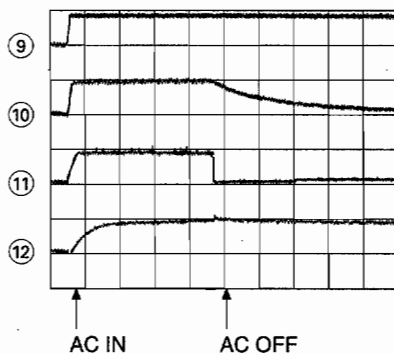

### [ Put AC at BACK UP Timer ]

- ⑬ IC901 Pin ⑨① (VCC) VOLT/DIV: 5V  
TIME/DIV: 500mS
- ⑭ IC901 Pin ④①① (AVREF)
- ⑮ IC901 Pin ③④ (AC OFF)
- ⑯ IC901 Pin ③⑤ (RESET)

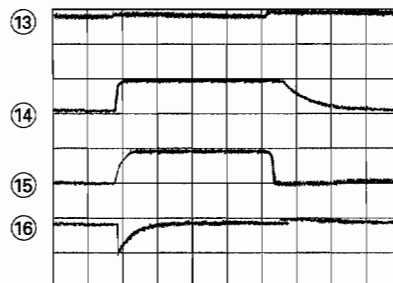



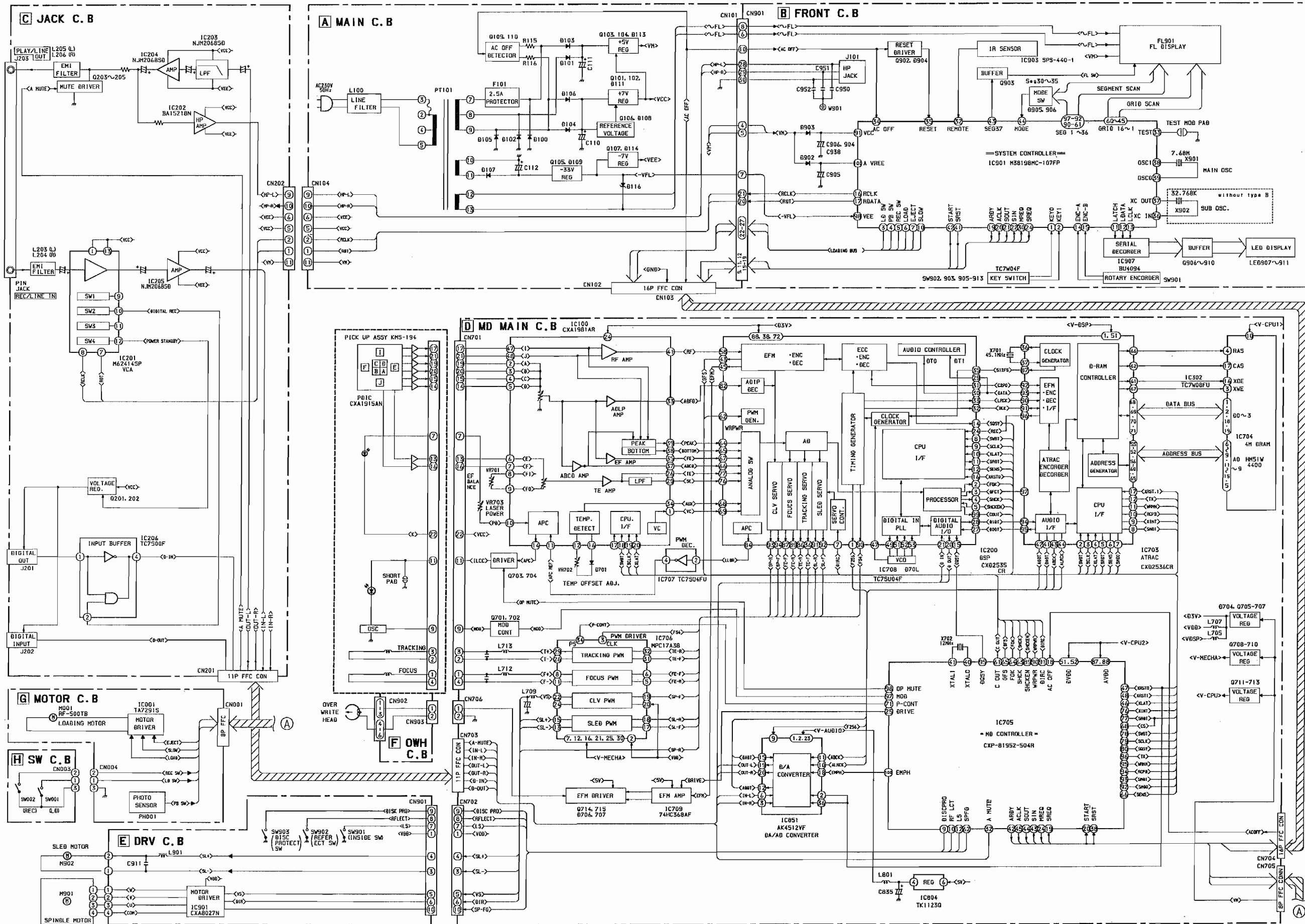

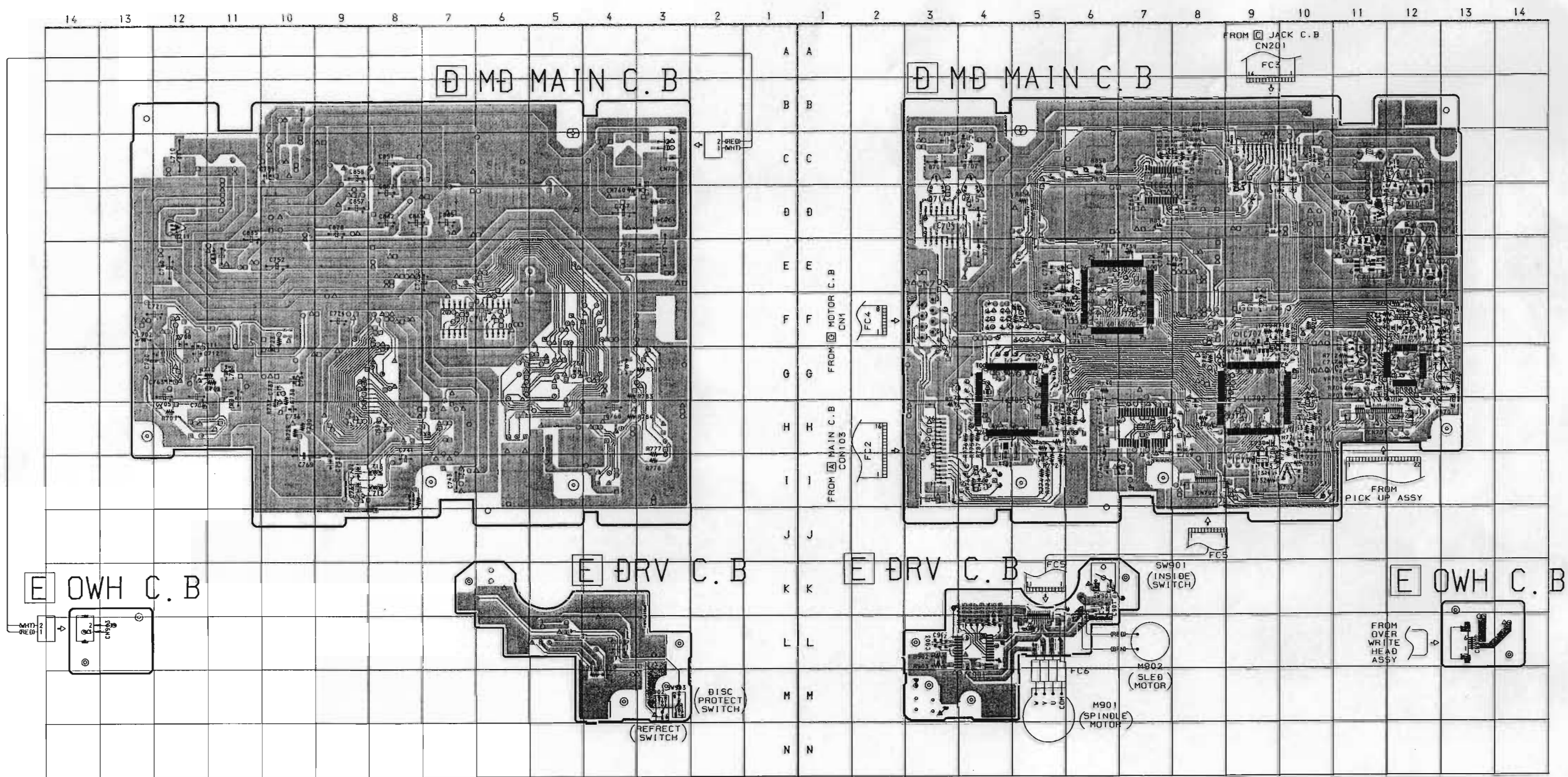



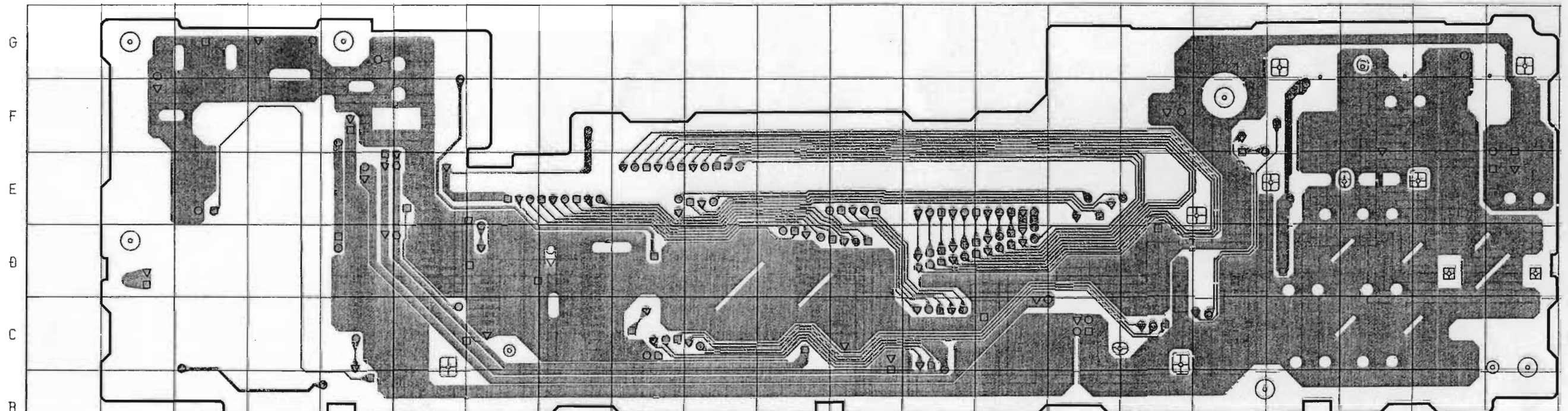

B FRONT C. B

1 2 3 4 5 6 7 8 9 10 11 12 13 14 15 16 17 18 19 20 21  
 I 2 3 4 5 6 7 8 9 10 11 12 13 14 15 16 17 18 19 20 21

B FRONT C. B

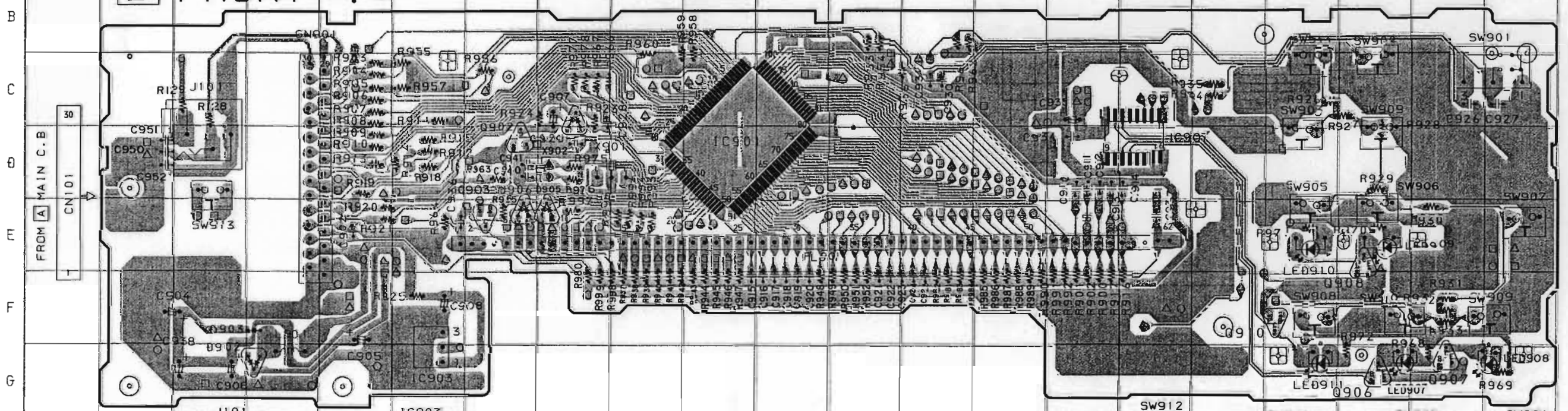

J101 PHONES  
 SW913 POWER

IC903 (SENSOR)

SW912

SW911 [ ] DISPLAY	SW902 [ ] FUNCTION	SW901 [ ] MULTI JOG
SW903 [ ] EDIT	SW979 [ ] ENTER	
SW905/LED910 [ ]	SW906/LED906 [ ]	SW907 [ ] RECORD
SW908/LED911 [ ]	SW910/LED907 [ ]	SW909/LED908 [ ]

SCHEMATIC DIAGRAM-2 (FRONT)

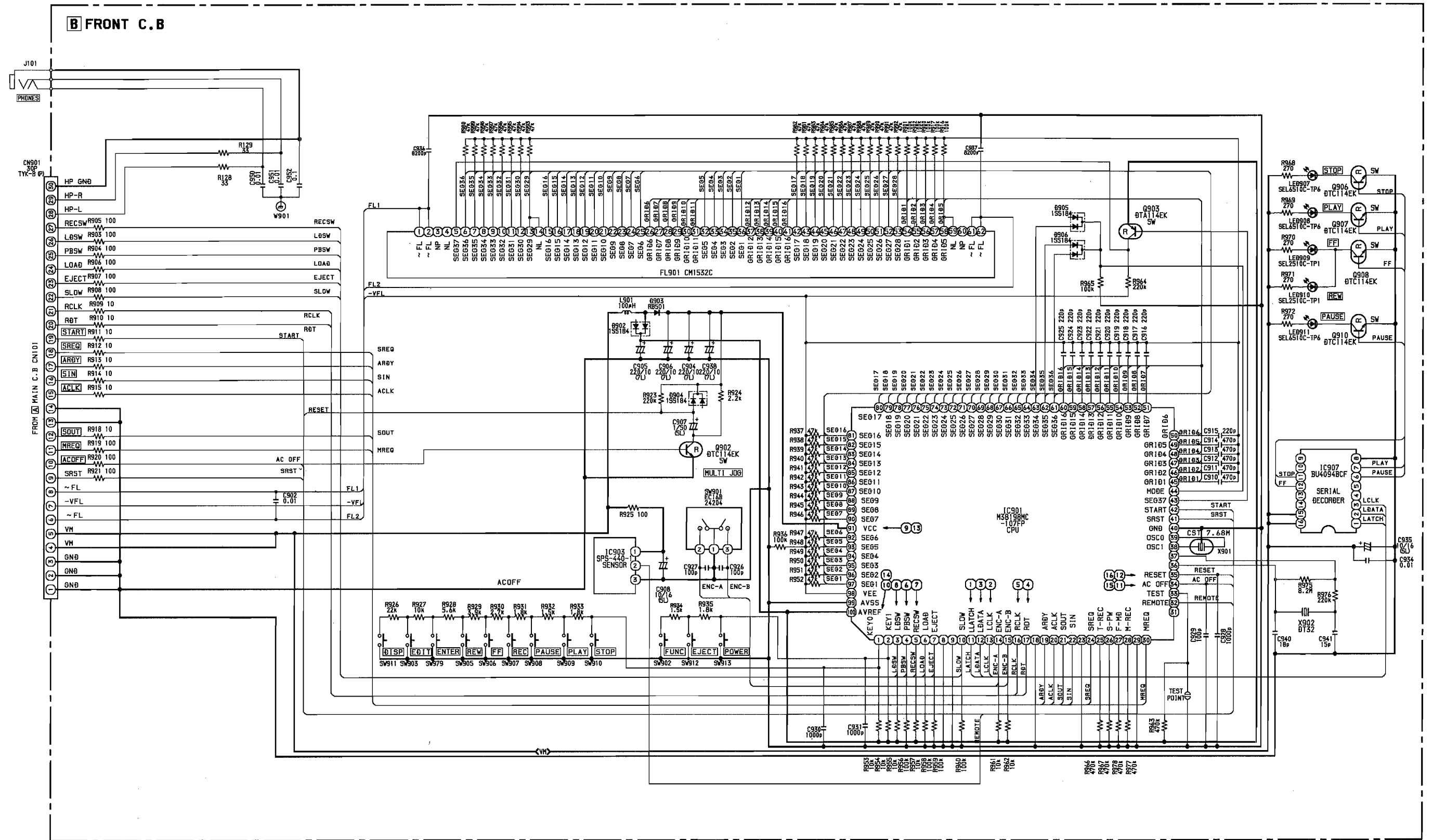

WIRING-3 (MAIN)

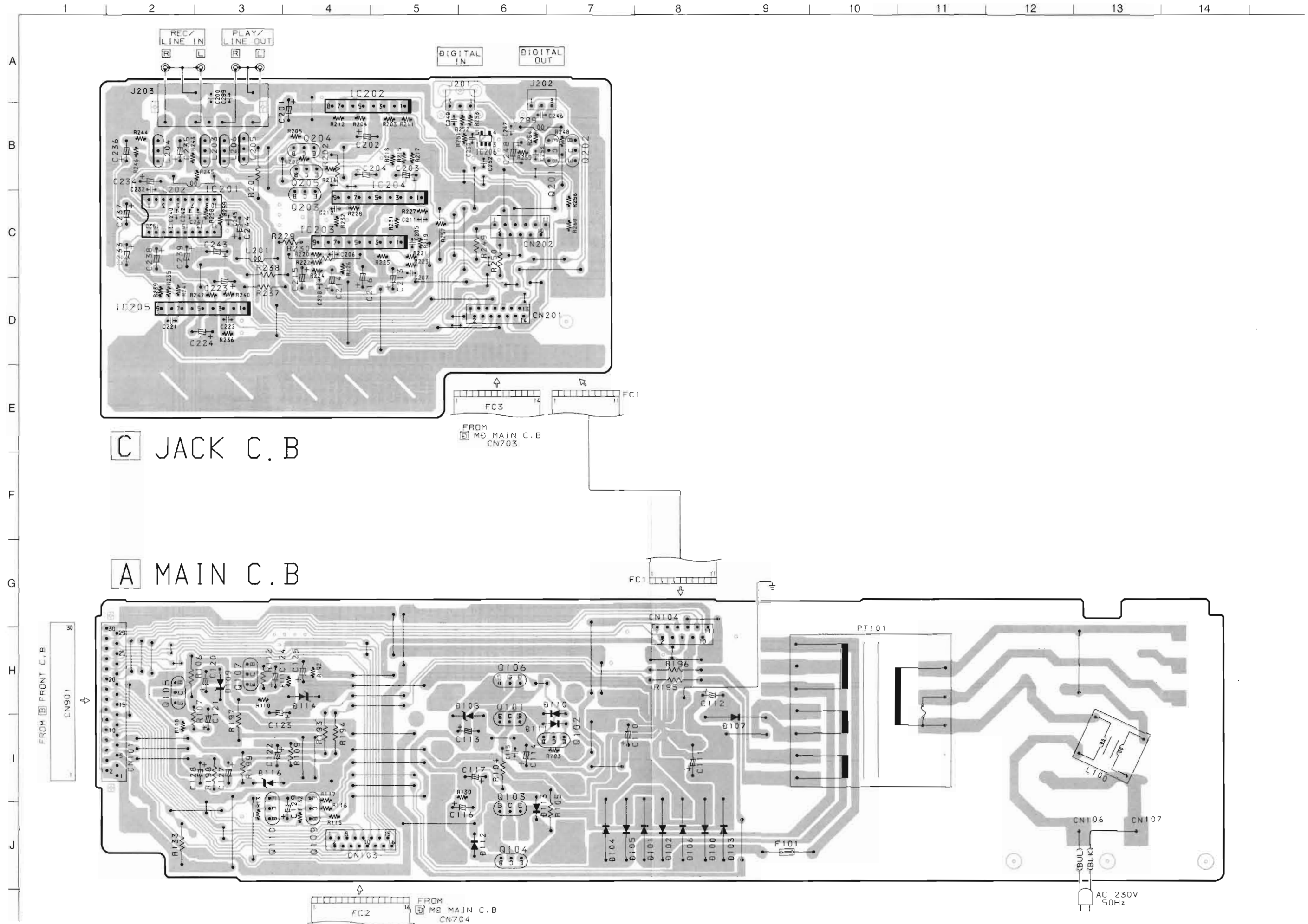

C JACK C.B

A MAIN C.B

SCHEMATIC DIAGRAM-3 (MAIN)

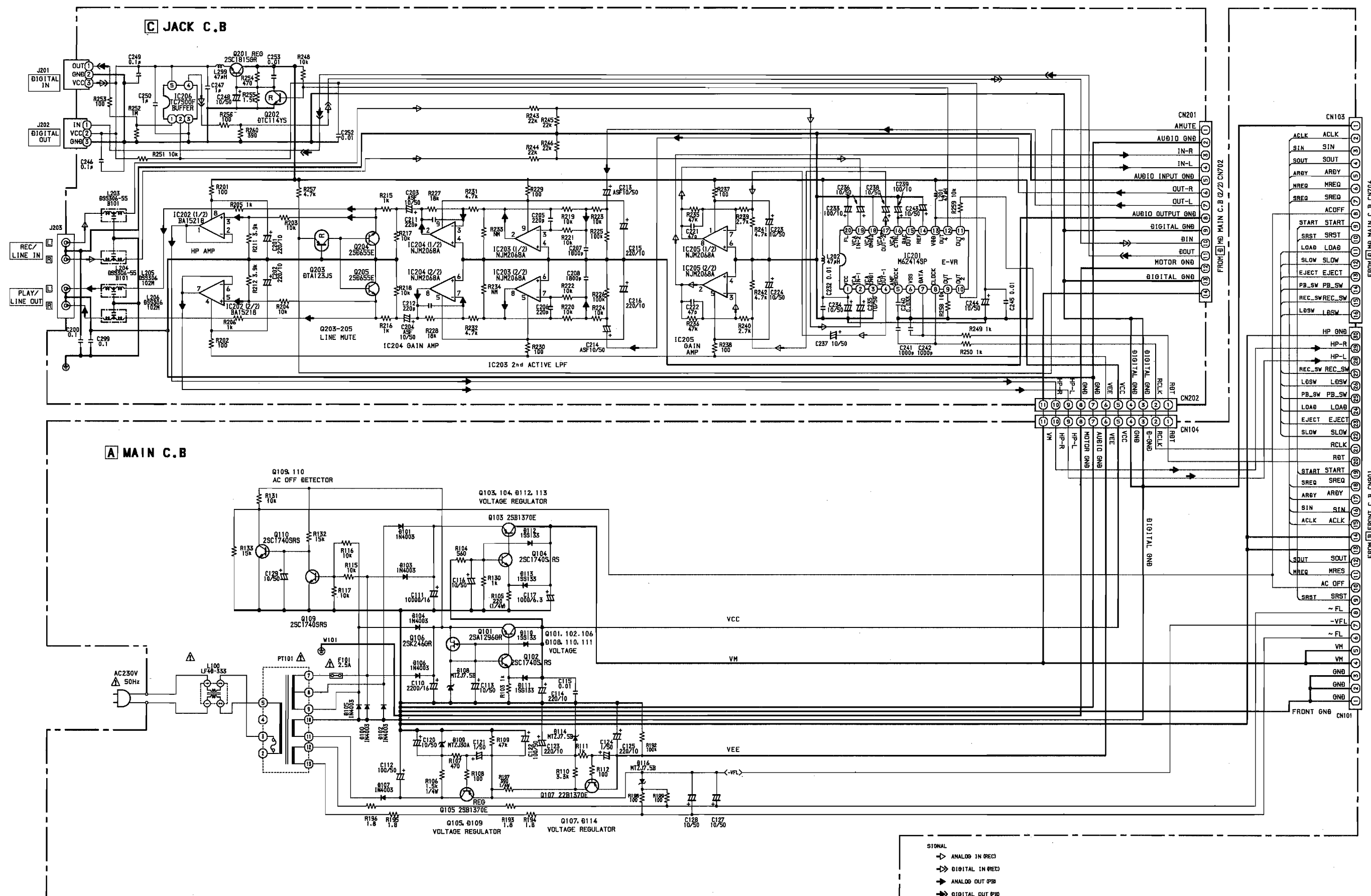

1 2 3 4 5 6 7

A  
B  
C  
D  
E  
F  
G  
H  
I  
J

# G MOTOR C.B

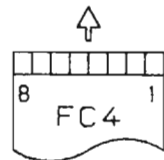
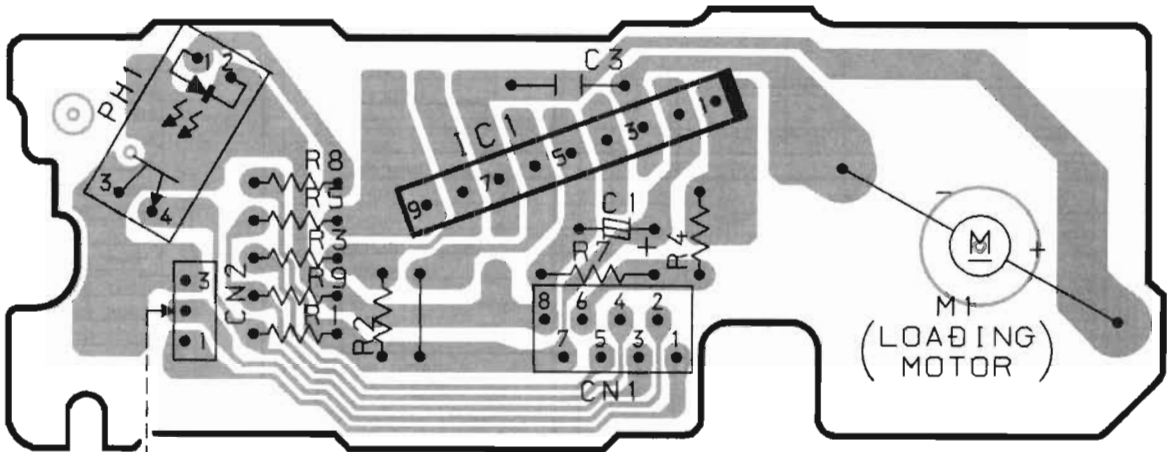

FROM [E] MØ MAIN  
CN705

# H SW C.B

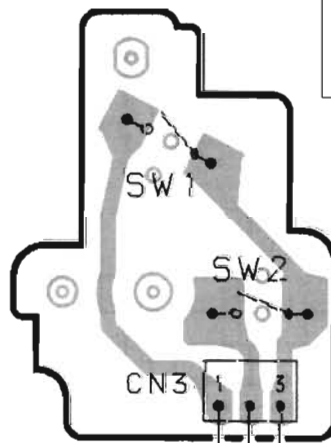

SW1  
(LD SW)

SW2  
(REC SW)

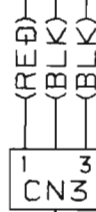



SCHEMATIC DIAGRAM-4 (MOTOR)

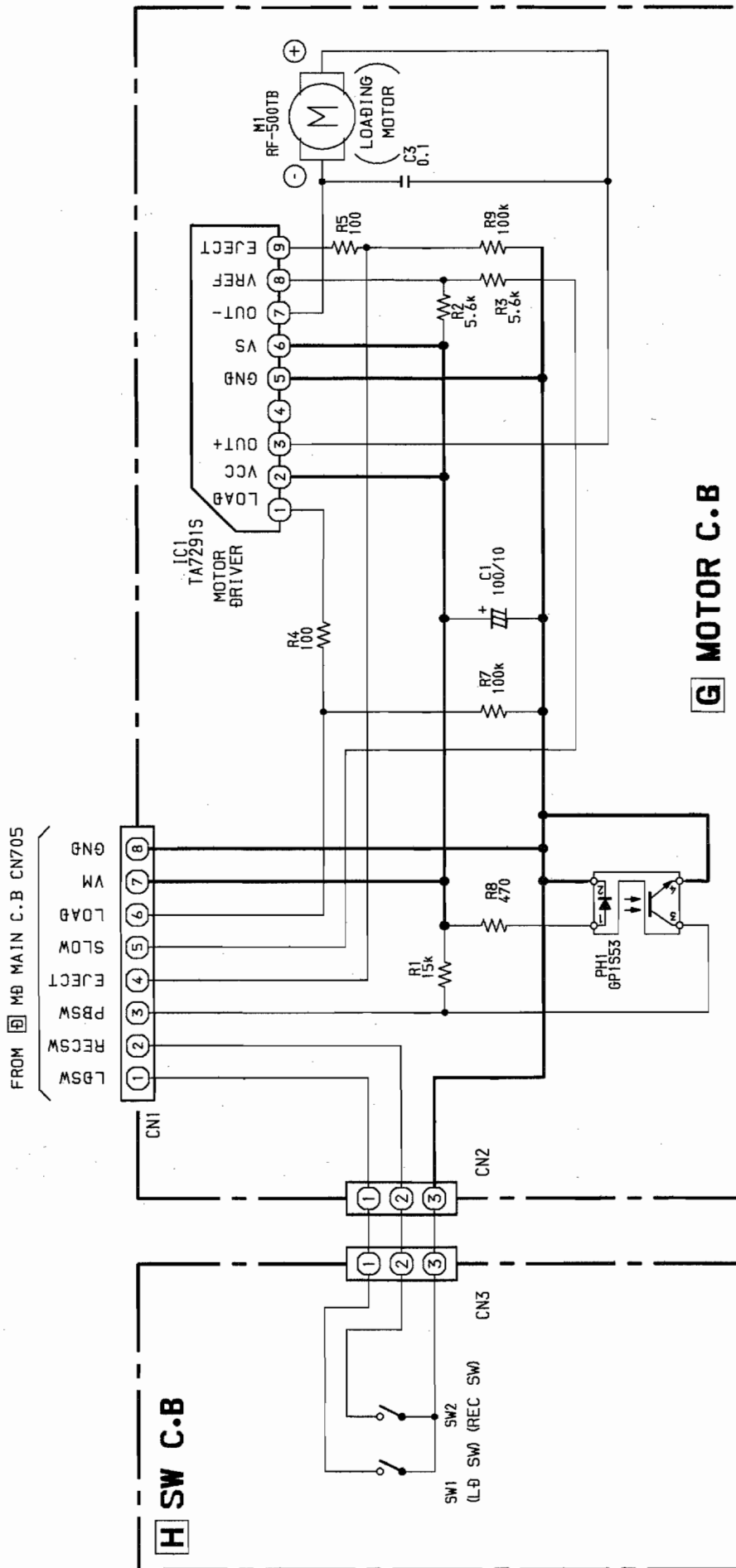

SCHEMATIC DIAGRAM-5 (DRV)

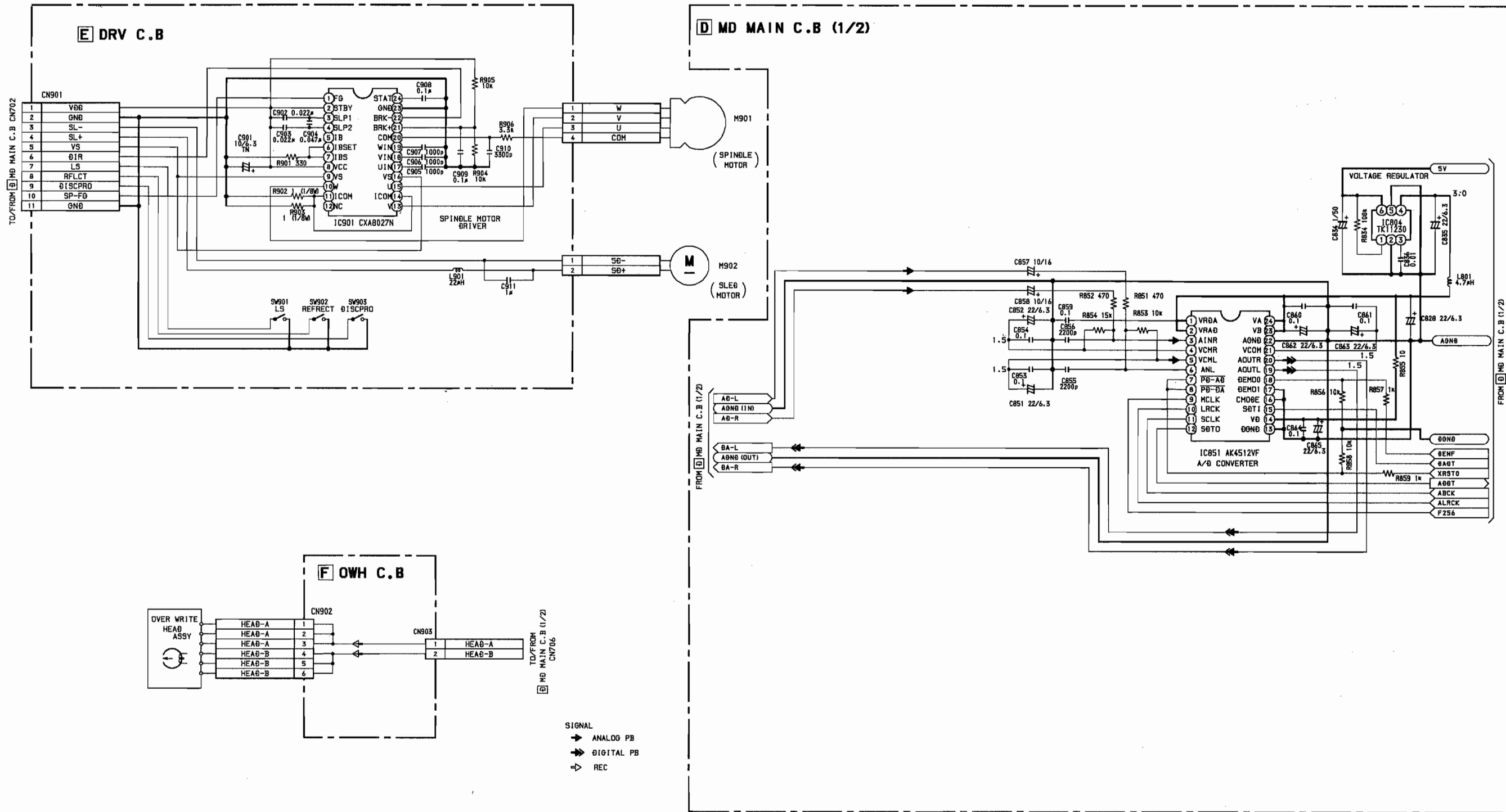

IC BLOCK DIAGRAM

IC, BU4094BCF

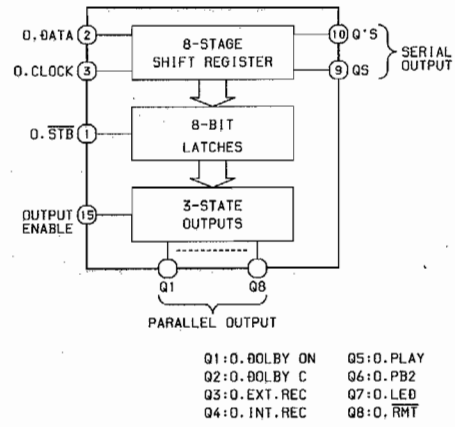

TRUTH TABLE

CLOCK	OUTPUT ENABLE	STROBE	DATA	PARALLEL OUTPUTS		SERIAL OUTPUTS	
				Q1	Qn	Q5	Q'S
L	L	x	x	Z	Z	Q7	NO CHG.
L	L	x	x	Z	Z	Q5	NO CHG.
L	H	L	x	NO CHG.	NO CHG.	Q7	NO CHG.
L	H	H	L	L	Qn-1	Q7	NO CHG.
L	H	H	H	H	Qn-1	Q7	NO CHG.
L	H	x	x	NO CHG.	NO CHG.	NO CHG.	Q5

Z = HIGH IMPEDANCE  
 x = DON'T CARE

IC, M62414SP-700

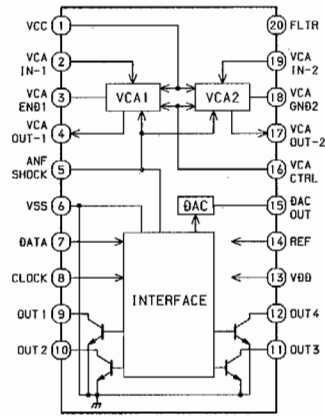

IC, MPC17A38ZVEL

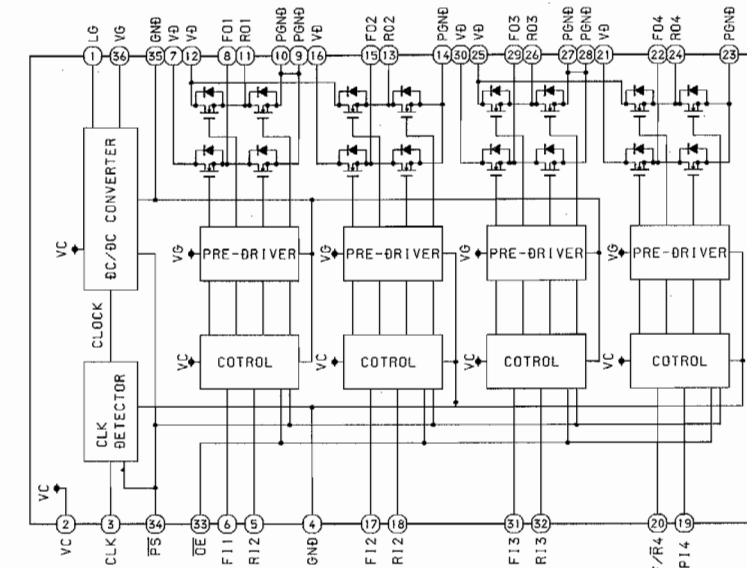

CLOCK DETECTOR

CLK	PS	OSC
X	H	AUTO
TOLK	H	SYNC
X	L	STOP

DRIVER

PS	OE	INPUT		OUTPUT~3		OUTPUT4	
PS	OE	F1, F/RT	R1, P1	FO	RO	FO	RO
H	L	L	L	L	L	L	L
H	L	L	H	L	H	L	H
H	L	H	L	H	L	L	L
H	L	H	H	H	L	L	H
H	H	X	X	L	L	L	L
L	X	X	X	Z	Z	Z	Z

\* Z: HIGH IMPEDANCE  
 \* PS: STOP  
 \* OE: LOW

IC, CXA8027N

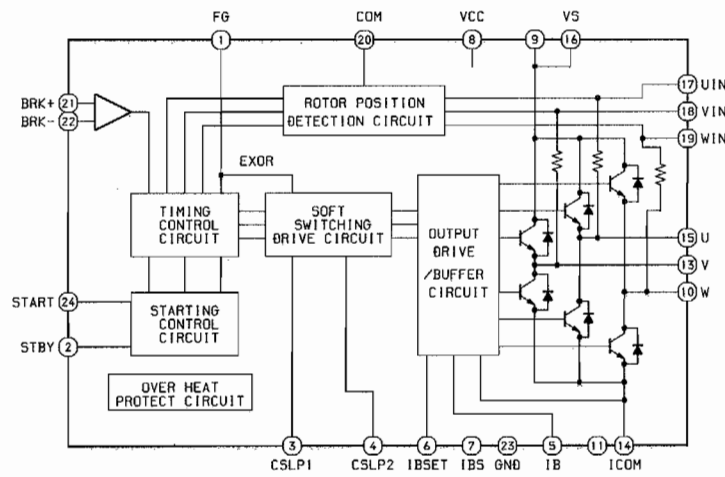

IC, TA7291

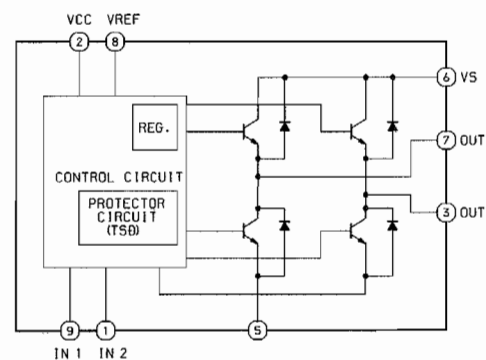

INPUT		OUTPUT		MODE
IN1	IN2	OUT1	OUT2	
0	0	∞	∞	STOP
1	0	H	L	CW
0	1	L	H	CCW
1	1	L	L	BRAKE

∞ : HI IMPEDANCE  
 NOTE : INPUT "H" ACTIVE

IC DESCRIPTION  
IC, M38198MC-107FP

Pin No.	Pin Name	I/O	Description
1, 2	KEY0, 1	I	Key input 0, 1 (AD).
3	LDSW	I	Loading control : LOAD switch input.
4	RECSW	I	Loading control : REC switch input.
5	PBSW	I	Loading control : PB switch input.
6	LOAD	O	Loading control : Motor output 1.
7	EJECT	O	Loading control : Motor output 2.
8, 9	—	—	GND
10	SLOW	O	Loading control : Motor speed SLOW output.
11	LLATCH	O	AI NAVI: Latch output.
12	DATA	O	AI NAVI: Data output.
13	LCLK	O	AI NAVI: Clock output.
14, 15	ENC-A, B	I	Rotary encoder phases A and B input.
16	RCLK	O	To electronic volume control Clock output (Not used).
17	RDATA	O	To electronic volume control Data output (Not used).
18	—	—	GND
19	ARDY	O	Main CPU handshake: Data ready output.
20	ACLK	I	Main CPU handshake: Clock input.
21	MD DISP OUT	O	Main CPU handshake: Data output. (LSB first).
22	MD DISP IN	I	Main CPU handshake: Data input (LSB first).
23	—	—	GND
24	SREQ	O	Main CPU handshake: Send request output.
25	T-REQ	I	Timer recording input
26	S-PW	I	Power switch input
27	F-MD	I	Function switch input
28	M-REC	O	Recording detection: "H" when recording
29	—	—	Not used. (Connected to GND)
30	MREQ	I	Main CPU handshake: Receive request input.
31	—	—	Not used.
32	REMOTE	I	Infra-red remote control input.
33	TEST	I	Test mode input. Turning on the main power while this pin is L enters the test mode.
34	ACOFF	I	AC power failure detection input. Judged as power failure when L is input to this pin.
35	RESET	I	Reset input.
36, 37	—	—	Not used.
38	OSC1	I	An external 8 MHz ceramic oscillator is connected to pin.
39	OSC2	O	An external 8 MHz ceramic oscillator is connected to pin.
40	GND	—	CPU digital GND.
41	SRST	O	Main CPU reset control output. Reset when this pin is set to L.
42	START	O	Hot start output of the main CPU. Re-start at L.
43	SEG37	O	FL's ever lighting segment control output.
44	MODE	I	MODE input (during initialization only).
45-60	GRID1-16	O	FL digit output.

Pin No.	Pin Name	I/O	Description
61	SEG36	O	FL segment output
62	SEG35	O	FL segment output.
63	SEG34	O	FL segment output.
64	SEG33	O	FL segment output.
65-90	SEG32-7	O	FL segment output.
91	VCC	I	4.2 to 4.7V is input to this pin.
92-97	SEG6-1	O	FL segment output.
98	VEE	I	Vdd -38V (-33V) is input to this pin.
99	AVSS	—	CPU analog GND.
100	AVREF	I	4.2 to 4.7V is input to this pin.

## IC, CXD2535CR

Pin No.	Pin Name	I/O	Description
1	FS256	O	256 Fs output. (11.2896 MHz)
2	FOK	O	Focus OK signal output. Focus OK at "H".
3	DFCT	O	Defect sense output. Defect at "H".
4	SHCK	O	Track jump sense output.
5	SHCKEN	I	Track jump sense enable input. Enable at "H".
6	WRPWR	I	Laser power switching input. Laser record power at "H". Laser playback power at "L".
7	DIRC	I	Track jump control signal.
8	SWDT	I	Microprocessor serial interface data input.
9	SCLK	I	Microprocessor serial interface shift clock input.
10	XLAT	I	Microprocessor serial interface latch input. Latch at fall-down.
11	SRDT	O	Microprocessor serial interface data output.
12	SENS	O	Internal status is output corresponding to microprocessor serial interface address.
13	ADSY	O	ADIP sync output
14	SQSY	O	Disc sub-code Q sync/ADIP sync output.
15	DQSY	O	U-bit CD or subcode Q sync output of the MD format is output when the source of the DIGITAL IN is CD or MD.
16	XRST	I	Reset input. Reset at "L".
17	TEST4	I	Test terminal. Connect to GND.
18	CLVSCK	O	Clock output for spindle servo evaluation. (5.6448 MHz).
19	TEST5	I	Test terminal. Connect to GND.
20	DOUT	O	Digital audio interface signal output.
21	DIN	I	Digital audio interface signal input.
22	FMCK	O	ADIP FM demodulation clock output.
23	ATER	O	ADIP CRC flag output. Error at "H".
24	REC	I	Switching between record and playback. Record at "H". Playback at "L".
25	DVSS	I	Digital GND.
26	DOVF	I	V-bit input of the signal to be output from the DOUT terminal.
27	DODT	I	Signal to be output from the DOUT terminal and audio data input for peak level detection.
28	DIDT	O	Audio data output of the signal which is input from the DIN terminal.
29	DTI	I	Record data input from CXD2536A.
30	DTO	O	Playback data output to CXD2536A during playback. "Z" during recording.
31	C2PO	O	C2 pointer of the playback data is output during playback. V-bit of the DIGITAL IN is output during digital recording. Analog recording at "L".
32	BCK	O	64 Fs output. (2.8224 MHz).
33	LRCK	O	Fs output (44.1 kHz).
34	XTAO	O	Crystal oscillator circuit output terminal. (Inverted output of the X'TAL terminal).
35	XTAI	I	Crystal oscillator circuit input terminal. (512 Fs = 22.5792 MHz).
36	MCLK	O	Master clock output. (512 Fs = 22.5792 MHz).
37	XBCK	O	BCK inverted output.

Pin No.	Pin Name	I/O	Description
38	DVDD	—	Digital power supply.
39	WDCK	O	2 Fs output. (88.2 kHz).
40	RFCK	O	Read frame clock output. (Fs/6).
41	WFCK	O	Write frame clock output.
42	GTOP	O	Monitoring the operating status of the frame sync protection window. Frame sync protection window is open at "H".
43	GFS	O	Frame sync OK at "H".
44	XPLCK	O	PLL clock output of the EFM decoder. (98 Fs = 4.3218 MHz).
45	EFMO	O	"L" output during playback. EFM (encode data) output during recording.
46	RAOF	O	RAM overflow output during playback.
47	MVCI	I	Clock input of the externally connected VCO for DIGITAL IN PLL.
48	TEST2	I	Test terminal. Connect to GND.
49	DIPD	O	DIGITAL IN PLL phase comparator output.
50	DVSS	—	Digital GND.
51	DICV	I	Voltage input to control the internal VCO for DIGITAL IN PLL.
52	DIFI	I	Input to filter when the internal VCO for DIGITAL IN PLL is used.
53	DIFO	O	Filter input when the internal VCO for DIGITAL IN PLL is used.
54	AVDD	—	Analog GND.
55	ASYO	O	Playback EFM full swing output. ("L" = V <sub>ss</sub> , "H" = V <sub>DD</sub> ).
56	ASYI	I	Playback EFM comparator slice voltage input.
57	BIAS	I	Playback comparator bias current input.
58	RFI	I	Playback EFM RF signal input/.
59	AVSS	—	Analog GND.
60	CLTV	I	Master PLL for playback digital PLL and also input control voltage to internal VCO for recording EFM PLL.
61	PCO	O	Master PLL for playback digital PLL and also phase comparator output to recording EFM PLL.
62	FILI	I	Master PLL for playback digital PLL and also filter input to recording EFM PLL.
63	FILO	O	Master PLL for playback digital PLL and also filter output to recording EFM PLL.
64	PEAK	I	Peak-hold signal input of laser light.
65	BOTM	I	Bottom-hold signal input of laser light.
66	ABCD	I	Laser light amount input signal.
67	FE	I	Focus error signal input.
68	AUX1	I	Auxiliary input-1.
69	VC	I	Center voltage input.
70	ADIO	O	Monitor output of the A/D converter input signal.
71	TEST3	I	Test terminal. Connect to GND.
72	AVDD	—	Analog GND.
73	ADRT	I	Input voltage indicating upper limit of A/D converter operation range.
74	ADRB	I	Input voltage indicating lower limit of A/D converter operation range.
75	AVSS	—	Analog GND.

Pin No.	Pin Name	I/O	Description
76	SE	I	Sled error signal input.
77	TE	I	Tracking error signal input.
78	AUX2	I	Auxiliary input-2.
79	DCHG	I	Connect to GND.
80	TEST6	I	Test terminal. Connect to GND.
81	APC	I	Test terminal. Connect to GND.
82	ADFG	I	ADIP binary FM signal (22.05 ±1 kHz) input.
83	TS25	I	Test terminal. Connect to GND.
84	LLDR	O	Laser drive output.
85	TRDR	O	Tracking servo drive output (-).
86	TFDR	O	Tracking servo drive output (+).
87	FFDR	O	Focus servo drive output (+).
88	DVDD	—	Digital power supply.
89	FRDR	O	Focus servo drive output (-).
90	FS4	O	4 Fs output. (1764 kHz).
91	SRDR	O	Slid servo drive output (-).
92	SFDR	O	Slid servo drive output (+).
93	SPRD	O	Spindle servo drive output (-).
94	SPFD	O	Spindle servo drive output (+).
95	DCLO	O	Serial data output for spindle servo evaluation.
96	DCLI	I	Serial data input for spindle servo evaluation.
97	XDCL	O	Serial data load signal output for spindle servo evaluation.
98	OFTRK	O	OFF-track signal output. OFF-track at "H".
99	COUT	O	Track jump count signal output.
100	DVSS	—	Digital GND.



# IC, CXD2536CR

Pin No.	Pin Name	I/O	Description
1	VDD	—	Power supply terminal.
2	SWDT	I	Microprocessor serial interface, data input.
3	SCLK	I	Microprocessor serial interface, shift clock input.
4	XLAT	I	Microprocessor serial interface, latch input. Latched at fall down.
5	SRDT	O	Microprocessor serial interface, data output.
6	SENS	O	Internal status output corresponding to the address of microprocessor serial interface.
7, 8	SMD0, SMD1	I	Serial command, command mode.
9	XINT	O	Interrupt request output terminal. "L" when interrupt status occurs.
10	RCPB	I	"H" at record mode, "L" at playback mode.
11	WRMN	I	"H" at write mode, "L" at monitor mode.
12	TX	I	Enable signal input terminal of the recording data output. Enable at "H".
13	VSS	—	GND.
14-16	TST0-TST2	I	Test terminal. Connect this pin to GND.
17	XRST	I	Reset input. Reset at "L".
18-21	TS0-TS3	I	Test terminal. Connect this pin to GND.
22-24	TST3-TST5	I	
25	VSS	—	GND.
26	AIRCPB	O	ATRAC block record/playback mode output. Record mode at "H". Playback mode at "L".
27-35	TST6-TST14	O	Test terminal. Leave this pin to open.
36	OSCO	O	Crystal oscillator circuit output terminal. (Inverted output of the OSC1 terminal).
37	OSCI	I	Crystal oscillator circuit input terminal. (1024 Fs).
38	VSS	—	GND.
39, 40	TST15, TST16	O	Test terminal. Leave this pin to open.
41	DOUT	O	Record monitor output/decoded audio data output.
42	ADIN	I	Analog record input terminal. (External A/D converter output is connected to this terminal.)
43	ABCK	O	XBCK (64 Fs) output terminal to external audio block.
44	ALRCK	O	LRCK (Fs) output terminal to external audio block.
45-47	SA2-SA0	O	SRAM address bus.
48, 49	A11, A10	O	RAM address bus.
50	VSS	—	GND.
51	VDD	—	Power supply terminal.
52-55	A03-A00	O	RAM address bus.
56-60	A04-A08	O	
61	XOE	O	RAM output enable.
62	XCAS	O	RAM $\overline{\text{CAS}}$ output.
63	VSS	O	GND.
64	XCS	O	RAM chip select. DRAM at "H". SRAM at "L".
65	A09	O	RAM address bus.
66	XRAS	O	RAM $\overline{\text{RAS}}$ output.

Pin No.	Pin Name	I/O	Description
67	XWE	O	RAM write enable.
68, 69	D1, D0	I/O	RAM data bus.
70-74	D2-D6	I/O	
75	VSS	—	GND.
76	D7	I/O	RAM data bus.
77	ERR	I/O	Data input/output terminal for C2PO exclusive RAM.
78	EXTC2R	I	Selector of C2PO exclusive RAM. "H" to use. "L" not to use.
79	BUSY	O	Busy output of RAM access. RAM access at "H".
80	EMP	O	The signal output indicating immediately before empty or full of the ATRAC data.
81	FUL	O	The signal output indicating immediately before full or empty of the ATRAC data.
82	EQL	O	ATRAC data empty. ("H" when ASC = DSC).
83	MDLK	O	Indicating main/sub of the record/playback data. Sub or linking at "H". Main at "L".
84	CPSY	O	Sync input to be inserted internally.
85, 86	CTMD1, CTMD0	O	Internal counter mode output.
87	SPO	O	512 Fs output.
88	VSS	—	GND.
89	MDSY	O	Sync detection output of the main data.
90	LRCK	I	LRCK (Fs) input terminal from the EFM encoder/decoder.
91	BCK	I	BCK (46 Fs) input terminal from the EFM encoder/decoder.
92	C2PO	I	C2PO input terminal from the EFM encoder/decoder.
93	DATA	I/O	Data input/output terminal from the EFM encoder/decoder.
94	DIDT	I	Digital recording input terminal.
95	DODT	O	Record monitor output/decode audio data output.
96	DIRCPB	O	Record/playback mode output to the EFM encoder/decoder. Record mode at "H". Playback mode at "L".
97	MIN	I	External monitor signal input terminal.
98	TST17	I	Test terminal. Connect this pin to VDD.
99	TST18	O	Test terminal. Leave this pin to open.
100	VSS	O	GND.

# IC, CXP81952-504R

Pin No.	Pin Name	I/O	Description
1-8	NC	—	Not used.
9	DISCPRO	I	Disc PROTECT switch input.
10	RFLCT	I	Disc REFLECT switch input.
11	B-CAS	O	DRAM self-refresh control output. (Not used).
12	LS	I	Pickup most-inner-circumference switch input.
13, 14	NC	—	Not used.
15	V-FLAG	I	Subcode V plug input of DIGITAL IN. (Not used.)
16, 17	NC	—	Not used.
18	ACOFF	I	Power failure input. Fixed to H.
19	S-REQ	I	Serial interface: Sub interrupt request signal.
20	START	I	Hot start input. Fixed to H.
21	B-RAS	O	DRAM self-refresh control output. (Not used).
22, 23	NC	—	Not used.
24	M-REQ	O	Serial interface: MD microprocessor interrupt request signal.
25	DRIVE	O	Record current control. "L" during recording.
26-28	NC	—	Not used.
29	DAPON	O	D/A converter ON/OFF control. H: ON. (Not used).
30	DMUTE	—	Not used. Open drain. (Not used).
31	REC	O	Power supply ON/OFF control for record circuit. H: ON. Open drain. (Not used).
32	AMUTE	O	Analog mute. H: Mute.
33-36	NC	—	Not used.
37	MP	I	Connected GND.
38	SRST	I	MD microprocessor starts up when it receives P-CON from system microprocessor. (Reset terminal).
39	DGND	—	Connected GND.
40	XTALO	O	Connected to 12 MHz ceramic oscillator.
41	XTALI	I	
42	ARDY	I	Serial interface: Ready signal.
43	SIN	I	Serial interface: SI signal.
44	SOUT	O	Serial interface: SO signal.
45	ACLK	O	Serial interface: Clock signal.
46	XLAT	O	Serial data strobe output.
47	XRST0	O	Reset signal to CXD2533BR/CXA1981. Reset at "L".
48	XRST1	O	Reset signal to CXD2536. Reset at "L".
49	NC	—	Not used.
50	AVSS	—	Connected to GND.
51	AVREF	—	Connected to power supply.
52	AVDD	—	
53-56	NC	—	Not used. (Pull up).
57-59	NC	—	Not used. (Connected to GND).
60	NC	—	Not used. (Pull up).

Pin No.	Pin Name	I/O	Description
61	COUT	I	Track jump count input.
62	SP-FG	I	Spindle FG input.
63	SHCK	I	Shock detection input.
64	FOK	I	FOK input. FOCUS ON at "H".
65	GFS	I	Guard frame sync input. Frame sync OK at "H".
66	SENS	I	CXD2535 internal status monitor input.
67	NC	—	Not used. (Connected to GND).
68	CS	I	Serial data strobe input.
69	NC	—	Not used.
70	EXTVCO	O	VCO ON/OFF control. ON at "L". (Not used).
71	P-CONT	O	DSP power supply control. Turn off the power of DSP/RF/MOTOR at "L".
72	RFSW	—	Not used.
73, 74	NC	—	
75	DQSY	I	Digital recording Sub-Q sync input.
76	XINT	I	Interrupt request from CXD2536. Interrupt at "L".
77	SRDT	I	CXD2536 serial data.
78	SWDT	O	CXD2536R/CXA1981A serial data.
79	SCLK	O	Serial clock of SRDT/SWDT.
80	SQSY	O	EFM subcode Q sync/ADIP sync.
81-83	NC	—	Not used.
84	NC	—	Not used. (Watch is not supported). Connected to GND.
85	NC	—	Not used. (Watch is not supported).
86	VSS	—	Connected to GND.
87, 88	VDD	—	Connected to power supply.
89	SHCKEN	O	Shock detection request output.
90	WRPWR	O	Laser power control output to CXD2536BR. Record power at "H".
91	DIRC	O	Track jump control.
92, 93	SMD0, SMD1	O	CXD2536R serial data control mode.
94	RCPB	O	CXD2536R record/playback control. Record mode at "H".
95	WRMN	O	ATRAC encode and external RAM write control.
96	TX	O	CXD2536R record data enable control. Enabled at "H".
97	MOD	O	Laser diode high frequency superimposition control.
98	OPMUTE	O	Laser diode control. ON at "H".
99	ADPON	O	AD converter power supply control. ON at "H". (Not used).
100	EMPH	O	AD converter emphasis control. ON at "L".

# IC, CXA1981AQ/AR

Pin No.	Pin Name	I/O	Description
1	VC	O	Vcc/2 voltage output.
2	A	I	Main beam servo signal A, current input.
3	B	I	Main beam servo signal B, current input.
4	C	I	Main beam servo signal C, current input.
5	D	I	Main beam servo signal D, current input.
6	E	I	Main beam servo signal E, current input.
7	F	I	Main beam servo signal F, current input.
8	FI	I	EF balance adjustment.
9	FO	O	EF balance adjustment.
10	PD	I	Amount of light, monitoring signal input.
11	APCREF	I	Reference voltage input for laser power setting.
12	TEMPI	I	External temperature sensor is connected to this terminal.
13	GND	—	GND.
14	AAPC	O	APC output.
15	DAPC	O	Test terminal. Open.
16	TEMPR	O	External temperature sensor is connected to this terminal. Reference voltage is output.
17	TST1	I	Test terminal. Connected to Vcc.
18	SWDT	I	Microprocessor serial interface, data input.
19	SCLK	I	Microprocessor serial interface, shift clock input.
20	XLAT	I	Microprocessor serial interface, latch input. Latch at "L".
21	VREF	O	Reference voltage output.
22	TST2	O	Test terminal. Open.
23	TST3	—	Test terminal. Open.
24	VCC	—	Power supply terminal.
25	TST4	I	Test terminal. Connected to Vcc.
26	TE	O	Tracking error output.
27	TLB	—	External capacitor for low-boosting the tracking error signal, is connected to this terminal.
28	CSLED	—	External capacitor of low-pass capacitor for the sled error signal, is connected to this terminal.
29	SE	O	Sled error signal output.
30	ADFM	O	ADIP FM signal output.
31	ADIN	I	ADIP signal comparator input.
32	ADAGC	—	External capacitor for ADIP AGC is connected to this terminal.
33	ADFG	O	ADIP 2 binary signal output.
34	AUX	O	I3 output/temperature signal output. The two signals are selected by the serial command.
35	FE	O	Focus error signal output.
36	FLB	—	External capacitor for low-boosting the focus error signal, is connected to this terminal.
37	ABCD	O	Light amount signal output from the main beam servo detector.
38	BOTM	O	RF/ABCD bottom hold signal output.

Pin No.	Pin Name	I/O	Description
39	PEAK	O	RF/ABCD peak hold signal output.
40	RFAGC	—	External capacitor for RF AGC is connected to this terminal.
41	RF	O	RF equalizer output.
42	ISSET	—	BPF (fo = 702 kHz, 22 kHz) and RF equalizer setting.
43	AGCI	I	RF AGC input.
44	RFO	O	RF amplifier output. Eye pattern check point.
45	MORFI	I	The input signal in which the RF signal from groove and the RF signal are mixed.
46	MORFO	O	RF signal (I-J) output from groove.
47	I	I	I-V converted RF signal I input.
48	J	I	I-V converted RF signal J input.

## IC, AK4512

Pin No.	Pin Name	I/O	Description
1	VRDA	I	Voltage Reference Input Pin for DAC, VA.
2	VRAD	I	Voltage Reference Input Pin for ADC, VA.
3	AINR	I	Rch Analog Input Pin.
4	VCMR	O	Rch Common Voltage Output Pin, VA/2. Connect a capacitor electrolytic of about 4.7 $\mu$ F and a capacitor ceramic of 0.1 $\mu$ F between this pin and AGND.
5	VCML	O	Lch Common Voltage Output Pin, VA/2. Connect a capacitor electrolytic of about 4.7 $\mu$ F and a capacitor ceramic of 0.1 $\mu$ F between this pin and AGND.
6	AINL	I	Lch Analog Input Pin.
7	PWAD	I	ADC Power-Down Mode Pin. "L": Power down
8	PWDA	I	DAC Power-Down Mode Pin. "L": Power down
9	MCLK	I	Master Clock Input Pin.
10	LRCK	I	Input/Output Channel Clock Pin.
11	SCLK	I	Audio Serial Data Clock Pin.
12	SDTO	O	Audio Serial Data Output Pin.
13	DGND	—	Digital Ground Pin.
14	VD	—	Digital Power Supply Pin.
15	SDTI	I	Audio Serial Data Input Pin.
16	CMODE	I	Master Clock Select Pin. "H": 384fs, "L": 256fs
17	DEM1	I	De-emphasis Frequency Select Pin.
18	DEM0	I	De-emphasis Frequency Select Pin.
19	AOUTL	O	Lch Analog Output Pin.
20	AOUTR	O	Rch Analog Output Pin.
21	VCOM	O	Common Voltage Output Pin, VA/2. Connect a capacitor electrolytic of about 4.7 $\mu$ F and a capacitor ceramic of 0.1 $\mu$ F between this pin and AGND.
22	AGND	—	Analog Ground Pin.
23	VB	—	Substrate Pin.
24	VA	—	Analog Power Supply Pin.

# FL GRID ASSIGNMENT/ANODE CONNECTION

TYPE: CM1532C  
ANODE & GRID ASSIGNMENT

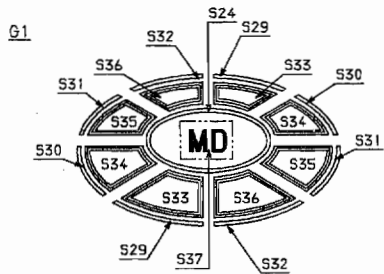
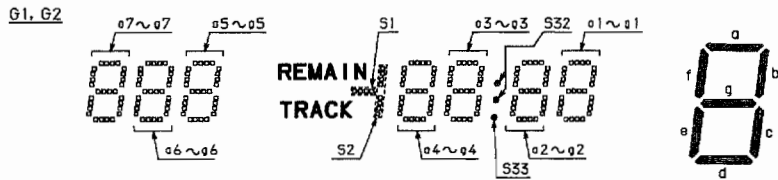
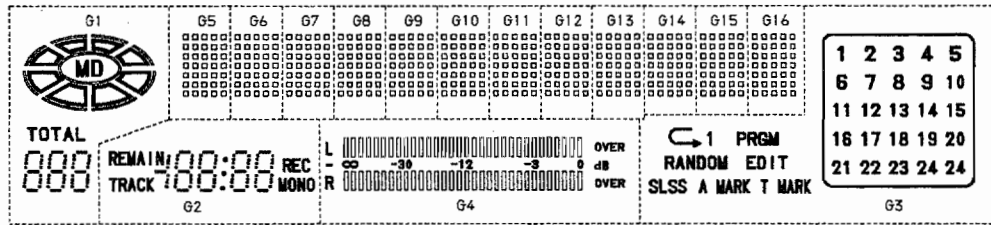

G5~G16

S1	S2	S3	S4	S5
S6	S7	S8	S9	S10
S11	S12	S13	S14	S15
S16	S17	S18	S19	S20
S21	S22	S23	S24	S25
S26	S27	S28	S29	S30
S31	S32	S33	S34	S35



TYPE:CM1532C  
 ANDOE & GRID ASSIGNMENT

	G1	G2	G3	G4	G5~G16
S1	TOTAL	oooo	1	S1	S1
S2		●	2	S2	S2
S3	a7	a4	3	S3	S3
S4	b7	b4	4	S4	S4
S5	c7	c4	5	S5	S5
S6	d7	d4	6	S6	S6
S7	e7	e4	7	S7	S7
S8	f7	f4	8	S8	S8
S9	g7	g4	9	S9	S9
S10	a6	a3	10	S10	S10
S11	b6	b3	11	S11	S11
S12	c6	c3	12	S12	S12
S13	d6	d3	13	S13	S13
S14	e6	e3	14	S14	S14
S15	f6	f3	15	S15	S15
S16	g6	g3	16	S16	S16
S17	a5	a2	17	S17	S17
S18	b5	b2	18	S18	S18
S19	c5	c2	19	S19	S19

	G1	G2	G3	G4	G5~G16
S20	d5	d2	20	S20	S20
S21	e5	e2	21	S21	S21
S22	f5	f2	22	S22	S22
S23	g5	g2	23	S23	S23
S24	○	a1	24	S24	S24
S25		b1	25	S25	S25
S26		c1	↻	S26	S26
S27		d1	↑	S27	S27
S28		e1	PROG	S28	S28
S29	S29	f1	RANDOM	S29	S29
S30	S30	g1	EXIT	S30	S30
S31	S31	REC	SLSS	S31	S31
S32	S32	○	A MARK	S32	S32
S33	S33	○	T MARK	S33	S33
S34	S34	REMAIN	(FRAME)	S34	S34
S35	S35	MONO		S35	S35
S36	S36	TRACK		S36	S36
S37	MB			S37	S37

TYPE:CM1532C  
 ANDOE ASSIGNMENT

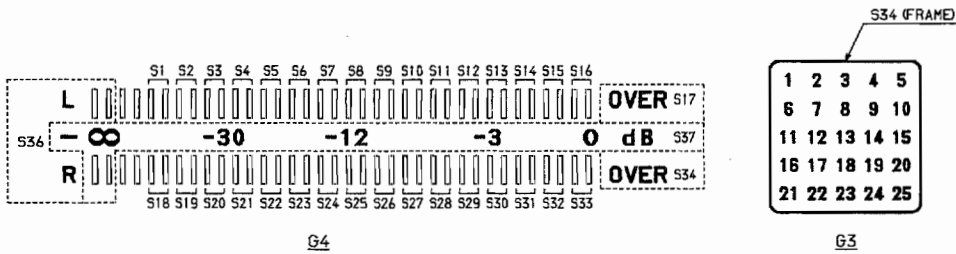

**D** MD MAIN C.B

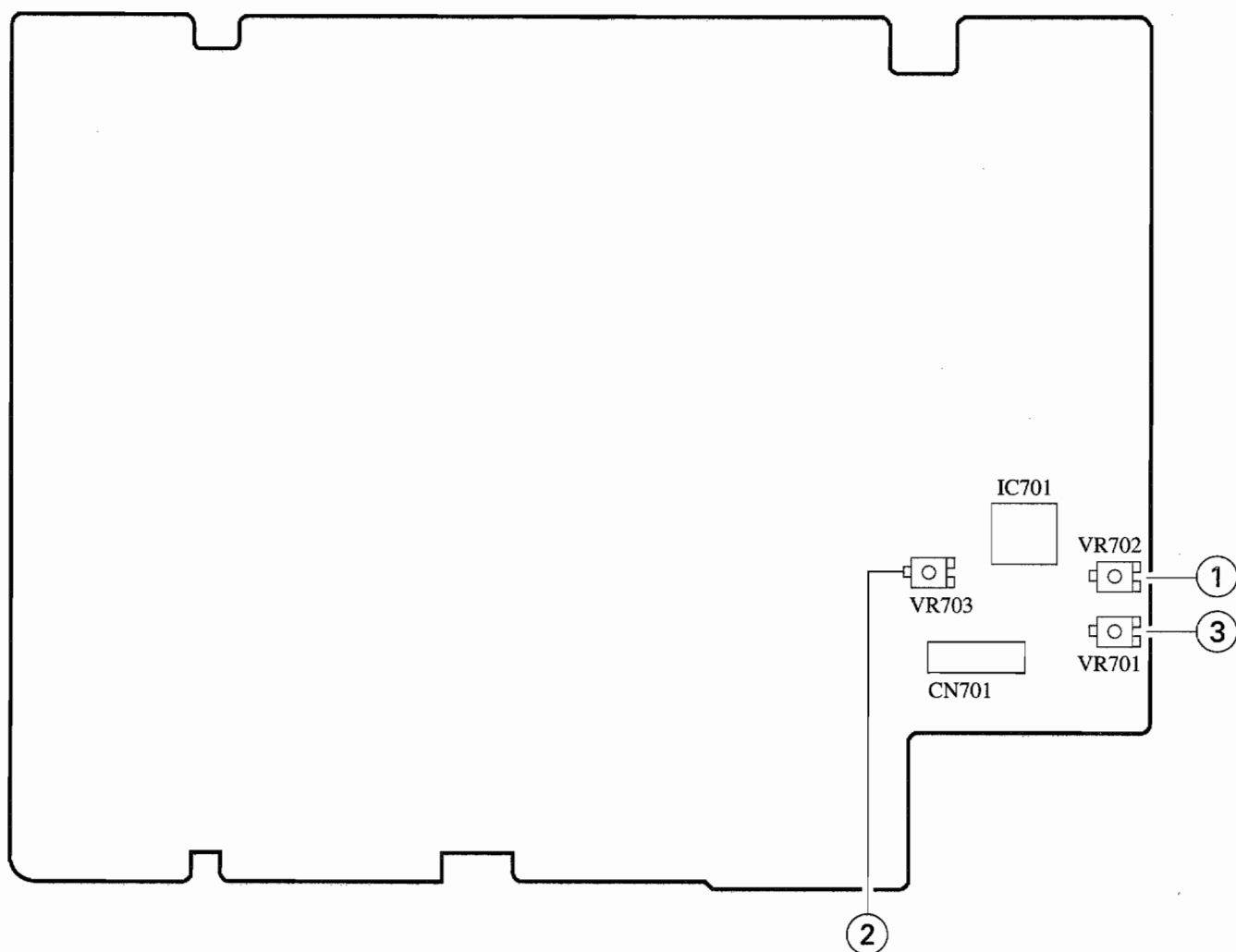

Perform all adjustments and checks while the machine is in the test mode.

## 1. Temperature Compensation Adjustment

Test point: To be checked on the FL display

Adjustment point: VR702

Tool: Thermometer

Turn the JOG dial while the machine is in the SERVO OFF mode and select the TEMP\$\*\* display and make adjustment until the temperature value shown on the thermometer and the value shown on the FL display agree. (Place a thermometer near the machine and measure room temperature.)

Perform the temperature compensation adjustment after removing the shield case.

Temperature	FL display
-7 °C to -2 °C	\$ B7 to \$ C9
-2 °C to 3 °C	\$ BF to \$ 01
3 °C to 8 °C	\$ C7 to \$ D9
8 °C to 13 °C	\$ CF to \$ E1
13 °C to 18 °C	\$ D7 to \$ E9
18 °C to 23 °C	\$ DF to \$ F1
23 °C to 28 °C	\$ E7 to \$ D9
28 °C to 33 °C	\$ EF to \$ 01
33 °C to 37 °C	\$ F7 to \$ 09

Values are shown in the hexadecimal notation on the FL display.

**Note)** Do not perform this adjustment when you cannot measure a room temperature because incorrect temperature compensation has an adverse effect on the recording.

## 2. Laser Power Adjustment

Test point: To be checked at the laser output of pickup

Adjustment point: VR703

Measuring equipment: Laser power meter

Method: Press the EDIT key four times while the machine is in the SERVO OFF mode. Check that the message "LASER WR" appears on the FL display. Adjust VR703 so that the laser power output is  $6.8 \pm 0.15$  mW.

**Note)** Adjust the output carefully because the pickup may be broken if the output exceeds 7.0 mW.

## 3. EF Balance Adjustment

Test point: To be checked on the FL display

Adjustment point: VR701

Test disc: MO disc (for record/playback)

Method: ① Press the PAUSE key in the ALL SV OFF mode to enter SELECT GRV.  
 ② Move the pickup a little from the innermost track toward the outer track.  
 ③ Press the PLAY key to establish FOCUS ON and press the EDIT key. ("LASER WR" appears on the monitor.)  
 ④ Turn JOG to adjust the VR701 so that the indication varies centering around SE\$80.

**Note)** The indication should stay within the range from SE\$71 to \$8E.

## 4. Focus, Tracking and Sled Gain Check

Test disc: TGYS-1 (for playback)

Method: ① Press the pause KEY in the ALL SV OFF mode to enter SELECT PIT.  
 ② Turn JOG three rotations after pressing the following operation buttons in the order of "PLAY" → "ENTER" → "STOP". Check that the FL display stays within the following range.

Gf: Focus gain → 28 to 5C  
 t: Tracking gain → 13 to 38  
 s: Sled gain → 13 to 38

\* The items that follows hereafter are not used in normal adjustment and check procedures.

## 5. Error Rate

### 1) Record/playback error rate

Test disc: MO Disk (for record/playback)

Test point: To be checked on the FL display

- Recording -

- ① Press the PAUSE key in the ALL SV OFF mode to enter SELECT GRV.
- ② Move the pickup a little from the innermost track toward the outer track.
- ③ Press the DISPLAY key to move down the OWH.
- ④ Press keys in the order of "REC" → "PLAY" → "ENTER" → "REC" to start recording. Check the disc address (recording start position) appearing in the left bottom of the screen. (Recording normally starts from the cluster around 600.)
- ⑤ After recording of about 15 seconds, press the STOP key to stop recording.
- ⑥ Press the FUNCTION key to move up the OWH.

- Error rate check-

- ⑦ Press keys in the order of "PLAY" → "ENTER" to enter ALL SV ON.
- ⑧ When the address indication shown in the left bottom of the screen shows the recording start position, turn JOG to select the error rate display.
- ⑨ Check that the error rate of the recorded segment is within the following values.  
 Cl: 0030 or less.  
 Err: 0000 (zero)

**Note)** If error rate is measured in the segment which is outside the recorded segment, the correct value cannot be obtained.

### 2) Playback error rate

#### (1) PIT disc (Playback use only)

Test disc: TGYS-1 (for playback use)

- ① Press the PAUSE key in the ALL SV OFF mode to enter SELECT PIT.
- ② Press the keys in the order: "PLAY" → "ENTER" to enter ALL SV ON.

- ③ Turn JOG to select the error rate display and check that the playback error rate is within the following values.  
Cl: 0050 or less.  
Err: 0000 (zero)

(2) MO PIT part (PIT segment in the MO disc)

Test disc: MO Disk (for record/playback)

- ① Press the PAUSE key in the ALL SV OFF mode to enter SELECT PIT.
- ② Move the pickup to the innermost track.
- ③ Press the keys in the order of "PLAY" → "ENTER" to enter ALL SV ON.
- ④ Turn JOG to select the error rate display and check that the error rate is within the following values.  
Cl: 0060 or less.  
Err: 0000 (zero)

(3) Recorded segment of the MO disc

- \* The error rate of recorded segment of the record/playback discs can be checked. This error rate tells whether the recording condition of a disc is good or not good.

Test disc: Recorded MO Disk

- ① Press the PAUSE key in the ALL SV OFF mode to enter SELECT GRV.
- ② Move the pickup a little from the innermost track toward the outer track.
- ③ Press the keys in the order: "PLAY" → "ENTER" to enter ALL SV ON.
- ④ Turn JOG to select the error rate display and check that the error rate is within the following value.  
Cl: 0060 or less. (Guide line value)  
Err: No need to check.

- Note) ① The MO disc recording starts from the cluster 32 or higher address. The error rate display of the cluster before 32 shows an incorrect value.
- ② When error rate of a recorded disc is measured in the test mode, the Err display value increases always because of the internal data processing. This is not abnormal. This mode checks the Cl point error rate only.

# TEST MODE

## 1. How to start the test mode and how to exit the test mode, and notes

### (1) How to start the test mode

AM-X10 has the two methods to start the test mode.

Method 1: Method of starting the test mode by shorting the test-lands

Short the test lands as shown in Fig-2.

Method 2: Method of starting the test mode by pressing the operation buttons

- 1) Turn off the main power so that the machine enters Power off (STANDBY) state. Confirm that the loading mechanism is in the EJECT state. (When the test mode is started while a disc is being inserted, the mechanism starts the EJECT operation so that the test mode cannot be started.)
- 2) While pressing the Power button, depress the STOP button. (Press the two buttons simultaneously.)

Then, press the following buttons in this order: DISPLAY → MD EJECT → DISPLAY → MD EJECT.

The message "Welcome to Mini disc TEST MODE" appears after all FL displays turn on and the test mode starts.

### (2) How to exit the test mode

Method 1: When the test mode is started by shorting the test lands: Unplug the AC power cord and remove soldering from the test land.

Method 2: When the test mode is started by pressing the operation buttons: Press the Power switch to turn off the main power, or alternately unplug the AC power cord.

The machine can exit the test mode when the EJECT button is pressed during the communication reliability test of the test mode.

### (3) Notes

- 1) The machine ignores all mechanical abnormalities and performs the test mode when the test mode is once started. Therefore, when any abnormal operations occur during the test mode, unplug the power cord immediately.
- 2) Recording and playback cannot be performed during the test mode.

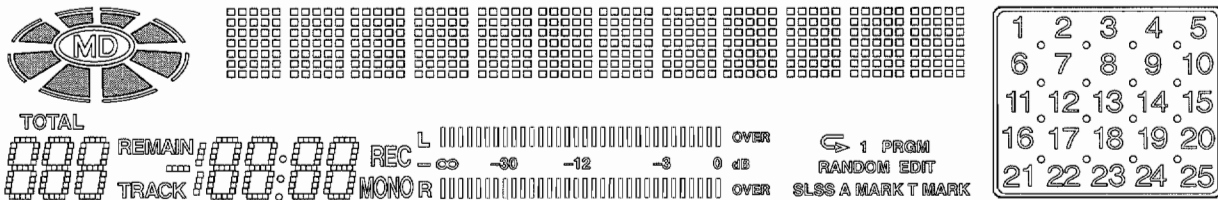

Fig-1. All segments of LCD turn on

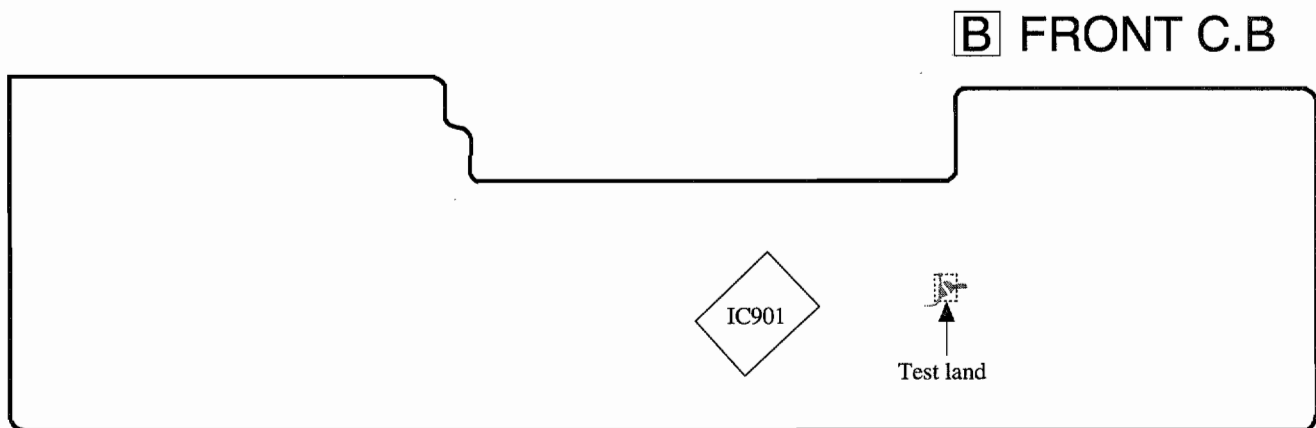

Fig-2. Test land location

## 2. Confirmation when test mode starts

### (1) Display

All FL displays turn on.

### (2) Playback system audio circuit can be checked.

- Circuits which can be checked ..... DAC, LINE amplifier, HP amplifier, digital output, LINE output and HP output.
- Output level check ..... 1 kHz, -12 dB (LINE output)

## 3. How to switch the system to the servo waiting mode

In order to switch the system to the servo waiting mode (ALL SV OFF), start up the test mode (all segment lighting mode) first, then press the EJECT button. In the servo waiting mode, the various servo test modes can be operated.

Note) The servo test modes cannot be operated directly from the all segment lighting mode.

## 4. Confirmation of various switch status

ON/OFF status (switch contact) of the various switches which are installed in the machine and especially in the mechanism of the machine can be checked from the FL display. Note that ON/OFF status corresponding to the frame only of each display while characters themselves turn on at all times.

Switch	Switch status	FL display		Discs to use
		SW ON	SW OFF	
REC PROTECT	When the write protection hole of the disc is closed (REC enabled).	<b>EDIT</b>	EDIT	Disc for recording
REFLECT	ON when high reflection (CD) disc is used.	<b>RANDOM</b>	RANDOM	Disc for playback
INNER	When pickup is located in the innermost track (LIMIT SW is ON).	<b>PRGM</b>	PRGM	—

\* LOADING, UNLOADING, and UP and DOWN of OWH can be checked with lighting status of the frames of three displays: SLSS, AUTOMARK and TIMEMARK.

Mechanism status	FL display		
1) LOADING status Three frames of SLSS, AUTOMARK and TIMEMARK turn on.	<b>SLSS</b>	<b>AUTOMARK</b>	<b>TIMEMARK</b>
2) UNLOADING status Frame of TIMEMARK only turns on.	SLSS	AUTOMARK	<b>TIMEMARK</b>
3) OWH DOWN status Frame of SLSS only turn on.	<b>SLSS</b>	AUTOMARK	TIMEMARK

## 5. Confirmation of sled movement

The movement of the sled motor and the pickup can be checked by pressing the **▶▶** key (to outer track) or **◀◀** key (to inner track). At the same time, the message "T. SLED FWD" is shown in the FL display while the mechanism is moving towards the outer track and "T. SLED RVS" is shown in the FL display while the mechanism is moving to the inner track.

## 6. Confirmation of laser output power

The laser output power can be changed by every pressing of the EDIT KEY while the machine is in the STOP mode. The laser output can be changed in the order starting from CD-R → MO-R → 1/2 LASER → MO-W → OFF, repeatedly. At the same time, the current mode can be checked by the message shown in the FL display and from the level meter.

Mode	Display
CD-R	LASER CD
MO-R	LASER MO
1/2 LASER	LASER 1/2
MO-W	LASER WR
OFF	LASER OFF

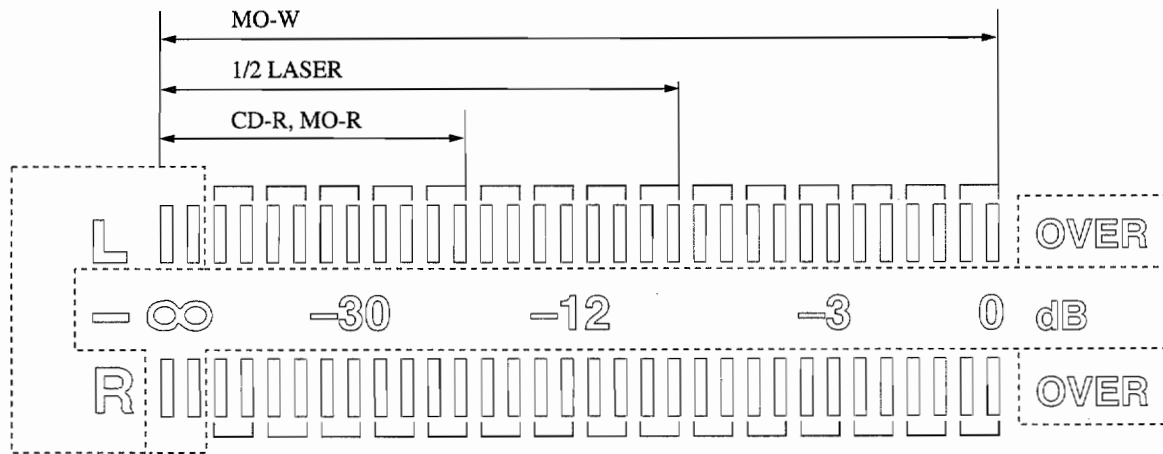

Fig-3. FL level meter (The level meter indication shows the operating modes, but not the amount of FL illumination.)

### 7. Confirmation of the loading mechanism operations

Operation of the loading mechanism can be checked using the DISPLAY and FUNCTION keys.

- \* DISPLAY key ..... LOADING
- \* FUNCTION key ..... UNLOADING (EJECT)

In addition, mechanism can be stopped at any position during unloading mode using this function. (During the loading mode, the mechanism performs loading automatically until it reaches the loading completed position when the KEY is pressed.)

### 8. OWH (Over Write Head)

Operation of the OWH can be checked by pressing the DISPLAY key or FUNCTION key while the mechanism is in the loading mode.

- \* DISPLAY KEY ..... OWH moves down.
- \* FUNCTION KEY ..... OWH moves up.

### 9. Confirmation of servo operations

#### (1) Focus search and spindle kick

The focus search and spindle kick can be checked by pressing the PLAY key while disc is not inserted. This mode is repeated until the STOP key is pressed. (Operation of the mechanism can be checked visually by putting the mechanism into the loading mode.)

#### (2) Focus servo

- 1) Insert a disc.
- 2) Press the PAUSE key and select an appropriate servo mode in accordance with the disc inserted.
  - \* Magneto-optical disc (MO disc) ..... Select GRV
  - \* Aluminum disc (CD software) ..... Select PIT
- 3) Press the PLAY key to set the focus servo to ON.

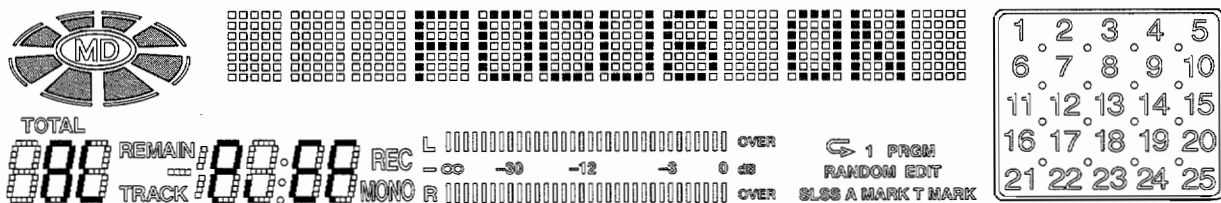

Fig-4. AL (Aluminum (CD) disc)

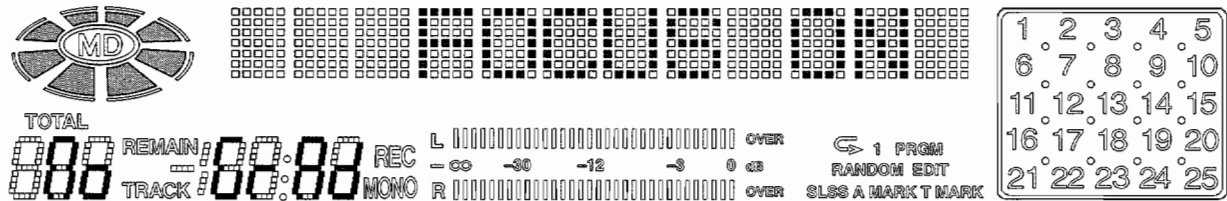

Fig-5. MO (Record/playback disc)

(3) All servo ON

When the ENTER key is pressed after the focus servo is turned, the tracking servo and the sled servo are both turned on. Then all servo loops are turned on and the message “ALL SV ON” appears on the FL display. At the same time, the disc address is indicated on left bottom of the display.

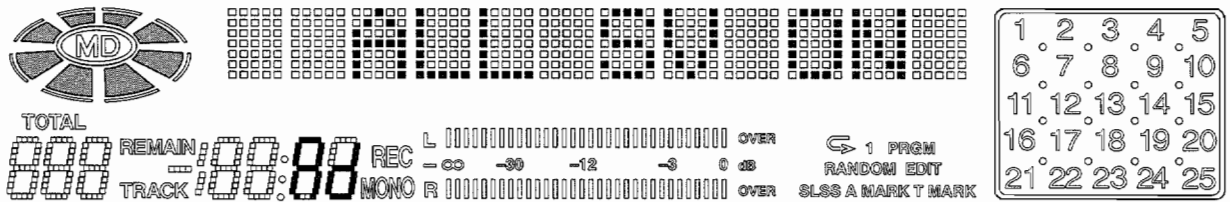

Fig-6. MO (Record/playback disc)

10. Testing reliability of communication

Pressing the EJECT button while the machine is in the servo mode enters the communication reliability test mode. This mode enables testing the communication between CPU of the front board and CPU of the MD board, and also checking the data bus line between the CPUs. Number of times of the communication test is shown in the center of the FL display (shown in units of TIMES) and number of Errors (shown as Err ○) is shown in the left bottom of the FL display. Communication between the CPUs can be judged to operate normally if error is zero or if “E3” or “E4” does not appear up until around 1000 TIMES of the test.

The machine can exit the test mode when the EJECT mode is pressed after completing the communication reliability test.



# MECHANICAL EXPLODED VIEW 1/1

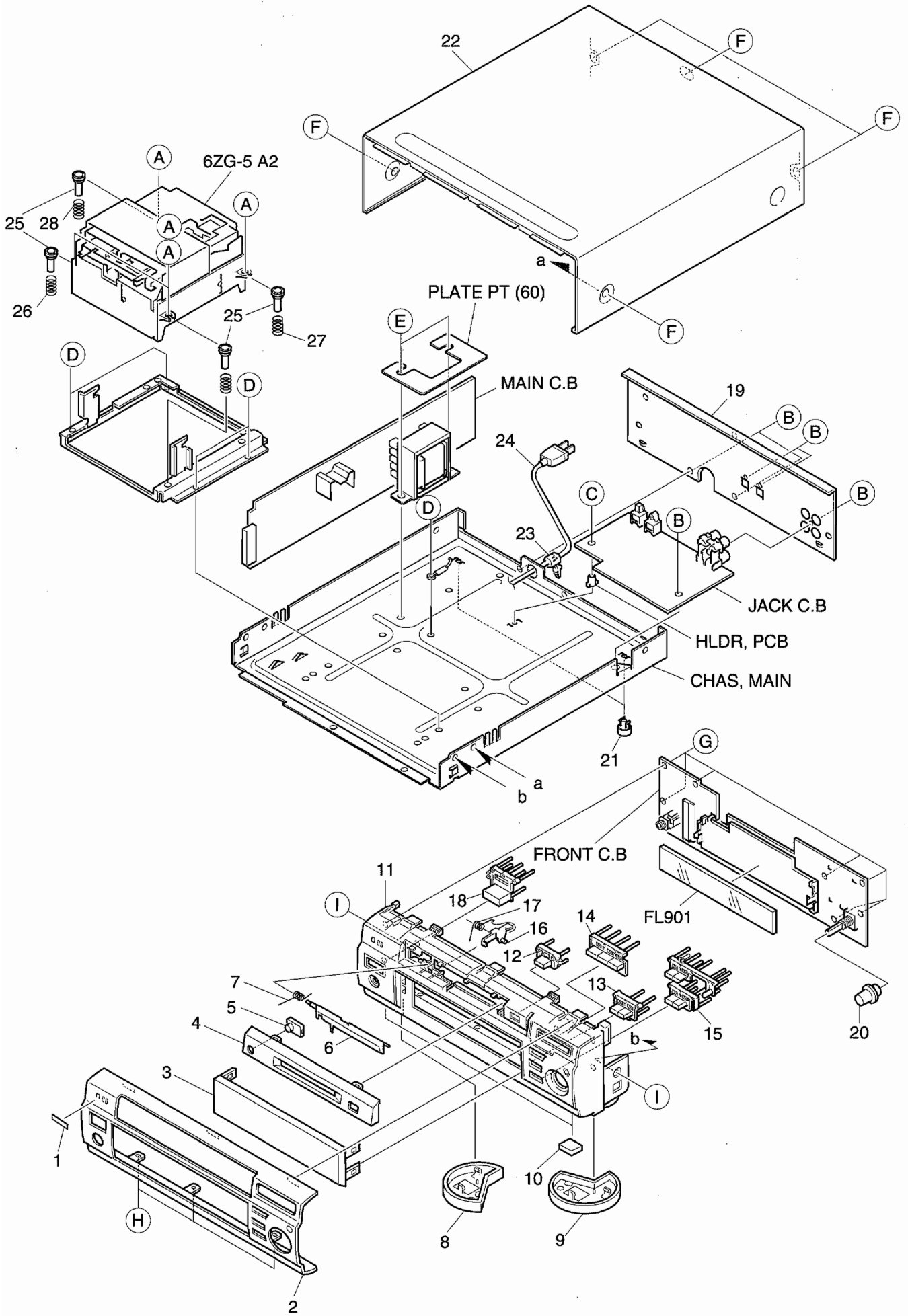

# MECHANICAL PARTS LIST 1/1

DESCRIPTIONで判断できない物は "REFERENCE NAME LIST" を参照してください。  
 If can't understand for Description please kindly refer to "REFERENCE NAME LIST".

REF. NO	PART NO.	KANRI NO.	DESCRIPTION	REF. NO	PART NO.	KANRI NO.	DESCRIPTION
1	87-B00-002-010		BADGE,AIWA 30 ABS SIL	22	87-NC1-005-010		CABI,STEEL
2	87-NC1-001-010		PANEL,FR SIL	21	87-085-213-010		FOOT, H 12.5
3	87-NC1-017-010		WINDOW,DISPLAY	23	87-085-185-010		BUSHING, AC CORD (E)
4	87-NC1-023-010		PANEL,DISC	24	87-050-079-010		AC CORD ASSY,E BLK
5	82-DW1-015-010		WINDOW,SENSOR	25	85-NC1-207-010		DMPR,MECHA
6	87-NC1-004-010		PANEL,MD	26	85-NC1-208-110		SPR-C,MECHA F
7	85-NC1-210-110		SPR-T,PANEL	27	85-NC1-212-110		SPR-C,MECHA R
8	87-NT1-015-010		RING,FOOT L	28	85-NC1-213-110		SPR-C,MECHA L
9	87-NT1-035-010		RING,FOOT R	A	85-NC1-211-010		S-SCREW,MECHA
10	80-VT1-202-010		FELT,12.5-15.5-2	B	87-067-579-010		BVT2+3-8 W/O SLOT
11	87-NC1-002-010		CABI,FR SIL	C	87-067-581-010		BVT2+3-15 W/O SLOT
12	87-NC1-018-010		KEY,EJECT	D	87-067-584-010		BVT2+3-6 W/O SLOT
13	87-NC1-010-010		KEY,EDIT	E	87-067-586-010		BVTT+4-8
14	87-NC1-007-010		KEY,ASSY PLAY	F	87-067-641-010		UTT2+3-8 W/O SLOT BLK
15	87-NC1-021-010		KEY,ASSY SEARCH	G	87-067-703-010		BVT2+3-10 W/O SLOT
16	85-NC1-205-210		LEVER,OPEN	H	87-067-777-010		BVTT+3-6 W,CONVEX BL
17	86-NF8-210-110		SPR-T,LVR	I	87-591-094-410		QIT+3-6
18	87-NC1-006-010		KEY,POWER	J	87-067-579-010		BVT2+3-8 W/O SLOT
19	87-NC1-020-010		PANEL,REAR EZS				
20	87-NC1-019-010		KNOB,RTRY DIAL				

MD MECHANISM EXPLODED VIEW 1/2

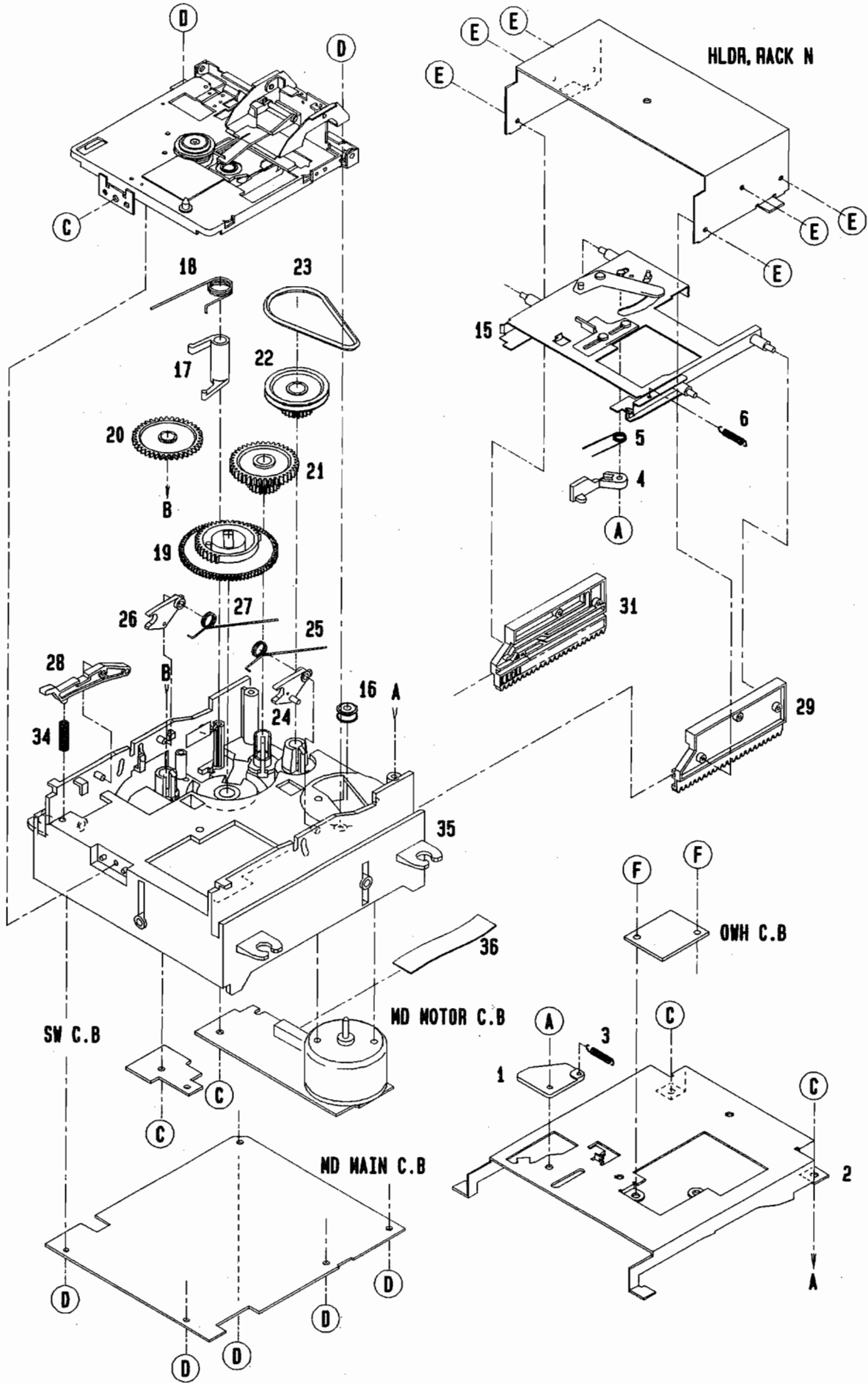

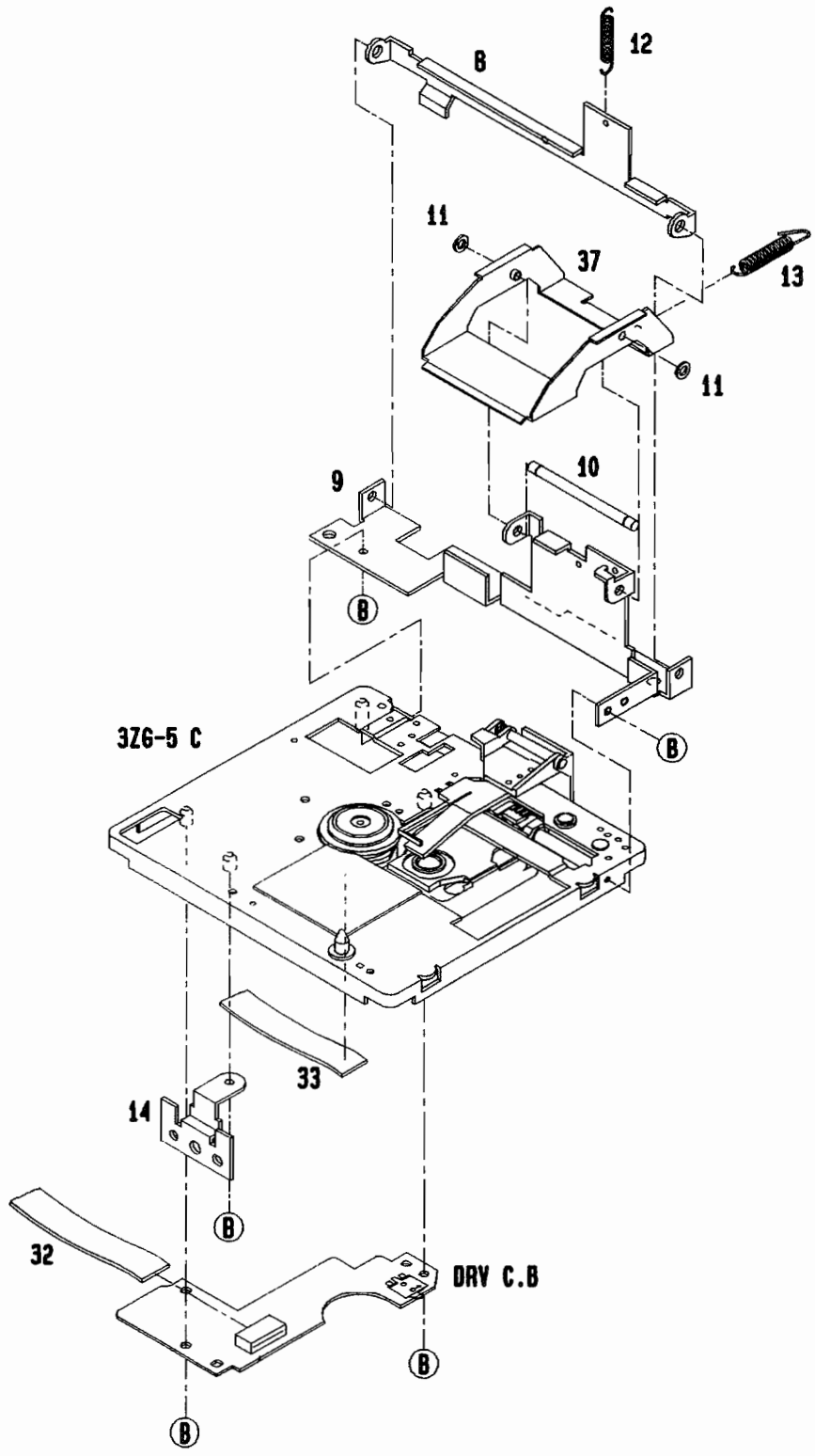

## MD MECHANISM PARTS LIST 1/2

DESCRIPTIONで判断できない物は "REFERENCE NAME LIST" を参照してください。  
 If can't understand for Description please kindly refer to "REFERENCE NAME LIST".

REF. NO	PART NO.	KANRI NO.	DESCRIPTION	REF. NO	PART NO.	KANRI NO.	DESCRIPTION
1	86-ZG2-226-210		GUIDE, EJECT	27	86-ZG2-234-010		SPR-T, LVR LOADING L
2	86-ZG2-250-410		HLLDR ASSY, LOADING	28	86-ZG2-224-210		LEVER, OPEN
3	86-ZG2-238-010		SPR-E, GUIDE EJECT	29	86-ZG2-206-010		RACK, LOADING R
4	86-ZG2-213-410		LEVER, CTRG	30	86-ZG2-223-010		HLLDR, RACK
5	86-ZG2-232-010		SPR-T, LVR CTRG	31	86-ZG2-205-110		RACK, LOADING L
6	86-ZG2-260-210		SPR, E LEVER SHUTTER	32	86-ZG2-617-010		FF-CABLE, 11P 0.5 125
8	86-ZG2-279-010		PLATE, ASSY REC N	33	86-ZG2-618-010		FF-CABLE, 4P 2 20MM
9	86-ZG2-272-010		HLLDR, MD RN	34	86-ZG2-236-010		SPR-C, LVR OPEN
10	86-ZG2-270-010		SHAFT, 2-30.3	35	86-ZG2-201-510		CHAS, LOADING
11	86-ZG2-259-010		WP, 1.5-4-0.3 BSU WO ADH	36	86-CD0-614-010		FF-CABLE, 8P 1.25 30MM
12	86-ZG2-243-010		SPR-E, PLATE HEAD	37	86-ZG2-273-110		PLATE, HEAD N
13	86-ZG2-244-010		SPR-E, PLATE REC	A	86-ZG2-253-010		W-P, 1.7-6-0.3 B W/O
14	86-ZG2-231-010		HLLDR, MD F	B	87-067-359-010		S-SCRW, +1.4-2.5 (BLK)
15	86-ZG2-202-910		HLLDR ASSY, CTRG	C	87-067-659-010		BVT2+2.6-8W/O SLOT B
16	81-ZG1-212-010		PULLY, LOAD MO	D	87-342-036-210		UT2+2-8
17	86-ZG2-225-110		LEVER, LOCK	E	87-B10-024-310		VT2+1.7-6 W/O
18	86-ZG2-237-010		SPR-T, LVR LOCK	F	87-351-530-310		VT2+1, 7-45
19	86-ZG2-229-110		GEAR, ASSIST				
20	86-ZG2-230-010		GEAR, IDLE H				
21	86-ZG2-228-010		GEAR, RELAY				
22	86-ZG2-227-010		PULLEY, LOADING				
23	86-ZG2-247-010		BELT, LOADING				
24	86-ZG2-208-110		LEVER, LOADING R				
25	86-ZG2-235-210		SPR-T, LVR LOADING R				
26	86-ZG2-207-110		LEVER, LOADING L				

# MD MECHANISM EXPLODED VIEW 2/2

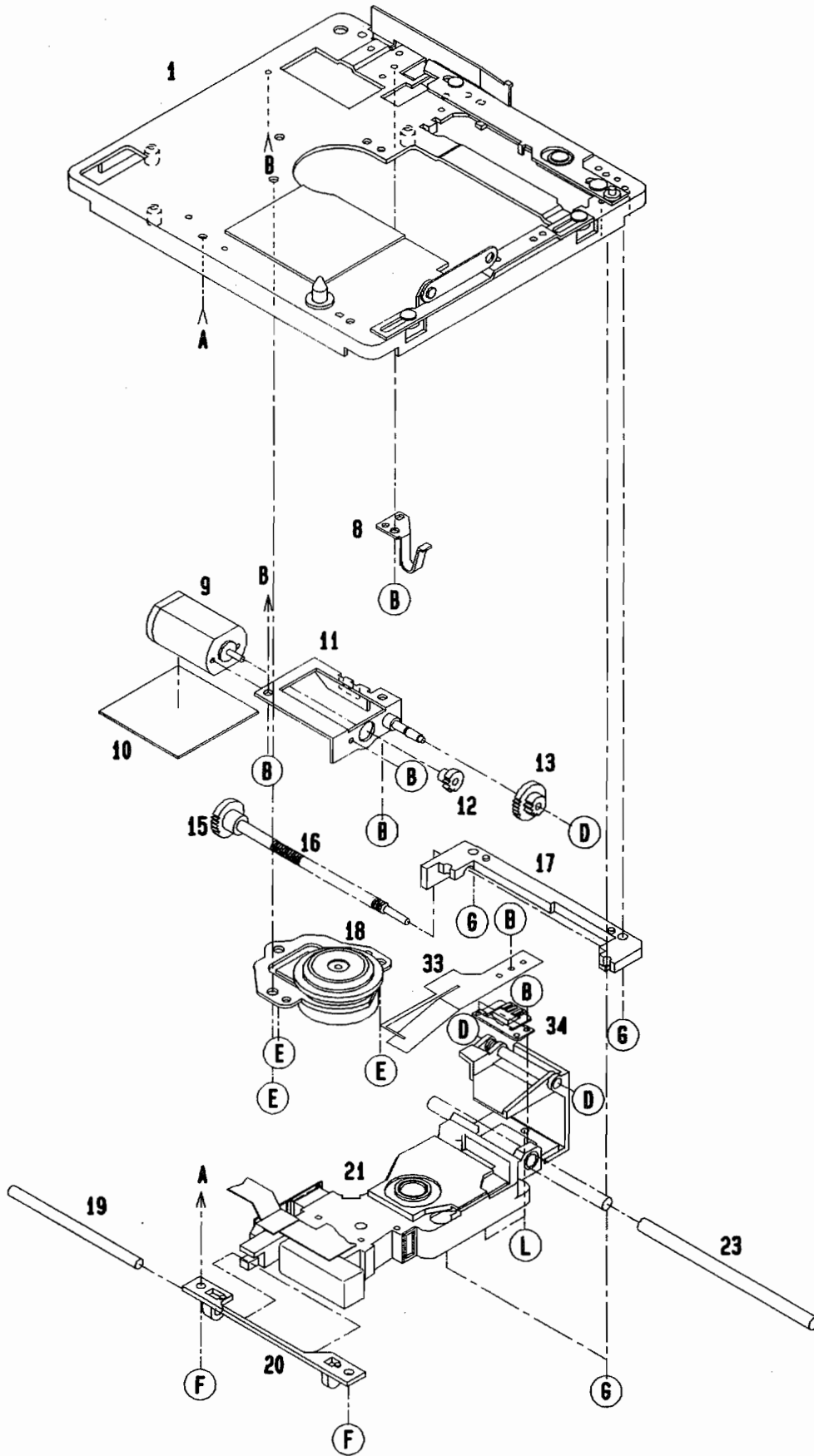

## MD MECHANISM PARTS LIST 2/2

DESCRIPTIONで判断できない物は "REFERENCE NAME LIST" を参照してください。  
 If can't understand for Description please kindly refer to "REFERENCE NAME LIST".

REF. NO	PART NO.	KANRI NO.	DESCRIPTION	REF. NO	PART NO.	KANRI NO.	DESCRIPTION
1	83-ZG5-290-010		CHAS,C ASSY	33	87-046-415-010		HEAD,RF320-74H
8	83-ZG5-265-010		SPR-P,GEAR P.U.	34	83-ZG5-247-110		SPR-P,INSERT ASSY
9	87-045-374-010		MOT,PFM20VK-7Z170	B	87-261-500-310		V+1.4-1.4 BLK(1)
10	83-ZG5-277-010		SH,20-12-0.05	D	87-078-123-010		PW,1.1-2.5-0.3 C
11	83-ZG5-261-010		HLDR,MOTOR P.U.ASSY	E	87-262-521-310		V+1.7-1.6 BLK
12	83-ZG5-268-010		GEAR,MOTOR P.U.	F	87-262-505-310		V+1.4-2.5 BLK(3)
13	83-ZG5-267-010		GEAR,P.U.B	G	87-262-507-310		V+1.4-3.0 BLK
15	83-ZG5-266-010		GEAR,P.U.A	L	87-262-523-310		V+1.7-2 BLK(3)
16	83-ZG5-254-110		SHAFT,PU GUIDE C				
17	83-ZG5-253-110		HLDR,PU GUIDE B				
18	87-045-373-110		MOT,SPINDOL				
19	83-ZG5-250-010		SHAFT,P.U.GUIDE A				
20	83-ZG5-252-110		HLDR,PU GUIDE A				
21	83-ZG5-297-010		PICK UP ASSY,2				
23	83-ZG5-251-010		SHAFT,P.U.GUIDE B				

## ACCESSORIES/PACKAGE LIST

DESCRIPTIONで判断できない物は "REFERENCE NAME LIST" を参照してください。  
If can't understand for Description please kindly refer to "REFERENCE NAME LIST".

REF. NO	PART NO.	KANRI NO.	DESCRIPTION
1	87-034-786-010		CORD PIN
2	87-B30-024-010		CABLE, OPTICAL MC-901



## REFERENCE NAME LIST

### ELECTRICAL SECTION

DESCRIPTION	REFERENCE NAME
ANT	ANTENNAS
C-	CHIP
C-CAP	CAP, CHIP
C-CAP TN	CAP, CHIP TANTALUM
C-COIL	COIL, CHIP
C-DI	DIODE, CHIP
C-DIODE	DIODE, CHIP
C-FET	FET, CHIP
C-FOTR	FILTER, CHIP
C-JACK	JACK, CHIP
C-LED	LED, CHIP
C-RES	RES, CHIP
C-SFR	SFR, CHIP
C-SLIDE SW	SLIDE SWITCH, CHIP
C-SW	SWITCH, CHIP
C-TR	TRANSISTOR, CHIP
C-VR	VOLUME, CHIP
C-ZENER	ZENER, CHIP
CAP, CER	CAP, CERA-SOL
CAP, E	CAP, ELECT
CAP, M/F	CAP, FILM
CAP, TC	CAP, CERA-SOL
CAP, TC-U	CAP, CERA-SOL SS
CAP, TN	CAP, TANTALUM
CERA FIL	FILTER, CERAMIC
CF	FILTER, CERAMIC
DL	DELAY LINE
E/CAP	CAP, ELECT
FILT	FILTER
FLTR	FILTER
FUSE RES	RES, FUSE
MOT	MOTOR
P-DIODE	PHOTO DIODE
P-SNSR	PHOTO SENSER
P-TR	PHOTO TRANSISTOR
POLY VARI	VARIABLE CAPACITOR
PPCAP	CAP, PP
PT	POWER TRANSFORMER
PTR, RES	PTR, MELF
RC	REMOTE CONTROLLER
RES NF	RES, NON-FLAMMABLE
RESO	RESONATOR
SHLD	SHIELD
SOL	SOLENOID
SPKR	SPEAKER
SW, LVR	SWITCH, LEVER
SW, RTRY	SWITCH, ROTARY
SW, SL	SWITCH, SLIDE
TC CAP	CAP, CERA-SOL
THMS	THERMISTOR
TR	TRANSISTOR
TRIMMER	CAP, TRIMMER
TUN-CAP	VARIABLE CAPACITOR
VIB, CER	RESONATOR, CERAMIC
VIB, XTAL	RESONATOR, CRYSTAL
VR	VOLUME
ZENER	DIODE, ZENER

### MECHANICAL SECTION

DESCRIPTION	REFERENCE NAME
ADHESHIVE	SHEET ADHESHIVE
AZ	AZIMUTH
BAR-ANT	BAR-ANTENNA
BAT	BATTERY
BATT	BATTERY
BRG	BEARING
BTN	BUTTON
CAB	CABINET
CASS	CASSETTE
CHAS	CHASSIS
CLR	COLLAR
CONT	CONTROL
CRSR	CURSOR
CU	CUSHION
CUSH	CUSHION
DIR	DIRECTION
DUBB	DUBBING
FL	FRONT LOADING
FLY-WHL	FLYWHEEL
FR	FRONT
FUN	FUNCTION
G-CU	G-CUSHION
HDL	HANDOL
HIMERON	CLOTH
HINGE, BAT	HINGE, BATTERY
HLDR	HOLDER
HT-SINK	HEAT SINK
IB	INSTRUCTION BOOKLET
IDLE	IDLER
IND, L-R	INDICATOR, L-R
KEY, CONT	KEY, CONTROL
KEY, PRGM	KEY, PROGRAM
KNOB, SL	KNOB, SLIDE
LBL	LABEL
LID, BATT	LID, BATTERY
LID, CASS	LID, CASSETTE
LVR	LEVER
P-SP	P-SPRING
PANEL, CONT	PANEL, CONTROL
PANEL, FR	PANEL, FRONT
PRGM	PROGRAM
PULLY, LOAD MO	PULLY, LOAD MOTOR
RBN	RIBBON
S-	SPECIAL
SEG	SEGMENT
SH	SHEET
SHLD-SH	SHIELD-SHEET
SL	SLIDE
SP	SPRING
SP-SCREW	SPECIAL-SCREW
SPACER, BAT	SPACER, BATTERY
SPR	SPRING
SPR-P	P-SPRING
SPR-PC-PUSH	P-SPRING, C-PUSH
T-SP	T-SPRING
TERM	TERMINAL
TRIG	TRIGGER
TUN	TUNING
VOL	VOLUME
W	WASHER
WHL	WHEEL
WORM-WHL	WORM-WHEEL

サービス技術ニュース	
番号	連絡内容
G-	-
G-	-
G-	-

**アイワ株式会社**  
**AIWA CO.,LTD.**

727105, 750038

Tokyo Japan